

# AQUADOPP

## CURRENT PROFILER

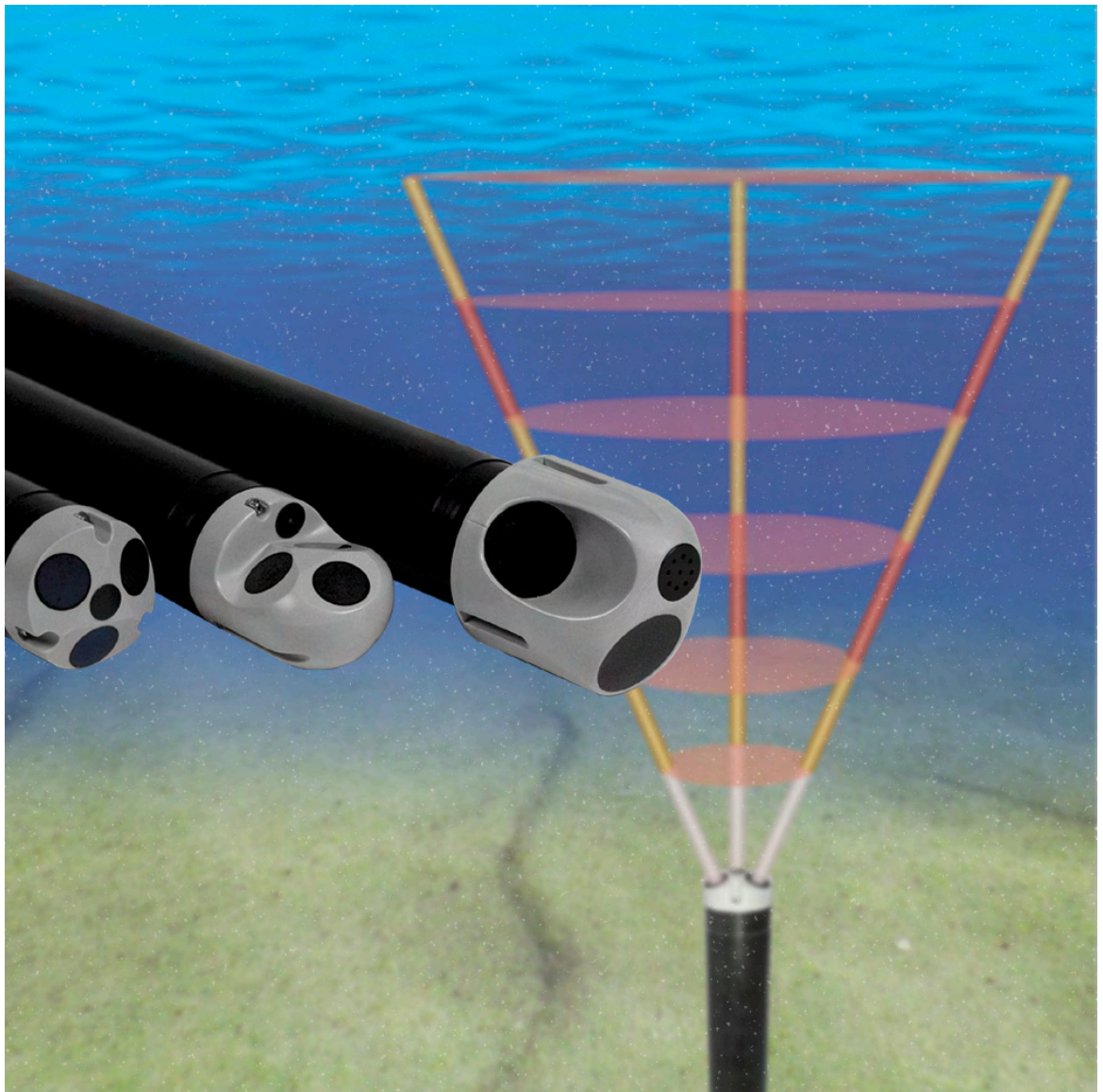

**USER GUIDE**  
JANUARY 2008





# AQUADOPP

## CURRENT PROFILER

Copyright © Nortek AS 2008. © September 2005. All rights reserved. This document may not—in whole or in part—be copied, photocopied, translated, converted or reduced to any electronic medium or machine-readable form without prior consent in writing from Nortek AS. Every effort has been made to ensure the accuracy of this manual. However, Nortek AS makes no warranties with respect to this documentation and disclaims any implied warranties of merchantability and fitness for a particular purpose. Nortek shall not be liable for any errors or for incidental or consequential damages in connection with the furnishing, performance or use of this manual or the examples herein. Nortek AS reserves the right to amend any of the information given in this manual in order to take account of new developments.

Microsoft, ActiveX, Windows, Windows NT, Win32 are either registered trademarks or trademarks of Microsoft Corporation in the United States and/or other countries. Other product names, logos, designs, titles, words or phrases mentioned within this publication may be trademarks, servicemarks, or tradenames of Nortek AS or other entities and may be registered in certain jurisdictions including internationally.

Nortek AS, Vangkroken 2, NO-1351 RUD, Norway.

Tel: +47 6717 4500 • Fax: +47 6713 6770 • e-mail: [inquiry@nortek.no](mailto:inquiry@nortek.no) • [www.nortek.no](http://www.nortek.no)



## Product Registration

When you receive your Nortek instrument it is important that you visit our website and register the instrument to activate the warranty, you'll find the form here:

[www.nortek-as.com/support/customer-warranty/warranty-form](http://www.nortek-as.com/support/customer-warranty/warranty-form)

## Software updates and technical support

For software updates and technical support:

[www.nortek-as.com/support](http://www.nortek-as.com/support)

## Nortek Forum Support

If you have comments, tips, suggestions for improvement or any other information that you think may be of interest then you should join the Nortek Forum:

[www.nortek-as.com/forum](http://www.nortek-as.com/forum)

The Forum offers a great opportunity for you to share your experiences of using Nortek instruments and allows you to benefit from other's.

## Your Feedback is appreciated

Your feedback is much appreciated. If you find errors, spelling mistakes, omissions or sections poorly explained or have any other comments on this manual please let us know, email us at:

[inquiry@nortek.no](mailto:inquiry@nortek.no)

## Contacting us

If you need more information, support or other assistance from us, do not hesitate to contact us:

**Nortek AS**  
**Vangkroken 2**  
**NO-1351 RUD, Norway**  
**Phone: +47 6717 4500, Fax: +47 6713 6770**  
**e-mail: [inquiry@nortek.no](mailto:inquiry@nortek.no)**

# DETAILS

## The Table of Contents

---

<b>CHAPTER 1</b>	<b>Introduction</b> .....	9
	Practical Use.....	9
	Getting Started.....	10
	Warranty.....	10
<b>CHAPTER 2</b>	<b>Technical Specifications</b> .....	11
	Echo intensity.....	11
	Transducer.....	11
	Standard sensors.....	12
	Analogue inputs.....	12
	Serial data communication.....	12
	Internal recording.....	12
	Software “AquaPro”.....	12
	Power.....	12
	Internal batteries.....	13
	Dimensions.....	13
	Materials.....	14
	Connectors.....	14
	Environmental.....	14
	Options.....	14
<b>CHAPTER 3</b>	<b>Technical Description</b> .....	15
	Aquadopp Profiler Components.....	15
	Cable Wiring.....	16
	Power Requirements Using RS 422.....	16
<b>CHAPTER 4</b>	<b>Functional Description</b> .....	19
	Modes of Operation.....	19
	Using the Doppler Effect.....	21
	Doppler Beams.....	22

	Coordinate Systems .....	22
	Attitude Correction.....	22
	Velocity Uncertainty .....	24
	Measuring Waves.....	24
<b>CHAPTER 5</b>	<b>Preparing the Instrumentation</b> .....	27
	Connecting the Battery.....	28
	Installing the AquaPro software on a PC .....	29
	Running the AquaPro Program .....	29
	Resources Available to Get You Started.....	29
	Running a Functionality Test .....	29
	A few words on the Break command .....	31
	Test the Recorder Function.....	34
	Starting with an Empty Memory.....	34
	Verifying the Internal Sensors .....	34
	Calibrating the Temperature Sensor.....	34
	Verifying the Tilt Sensor .....	35
	Setting the Pressure Sensor Offset.....	36
	Calibrating the Compass.....	36
	Upgrading the Firmware .....	38
	Mounting Guidelines .....	39
	Using Long Cables.....	40
	Changing the Baud Rate.....	40
<b>CHAPTER 6</b>	<b>Operation</b> .....	43
	Data Collection .....	43
	A Tour of the AquaPro Desktop .....	44
	The AquaPro Pull-down Menus.....	45
	Deployment Planning .....	46
	The Deployment Planning MenuStandard tab .....	47
	The Deployment Planning MenuAdvanced tab .....	48
	Wave Bursts .....	49
	Use with other Instruments .....	50
	Starting Recorder Deployment.....	52
	Setting the Instrument's Real Time Clock .....	52
	Stopping Recorder Deployment.....	53
<b>CHAPTER 7</b>	<b>Real Time Applications</b> .....	55
	Online Solutions .....	55
	Recording Data Internally as a Backup.....	56
	Online Viewing of Acquired Data.....	57
	Numerical View Options .....	57
	Graphical View Setup Options.....	60
	Customizing the Display .....	60
	Exporting a Graph .....	63
	The Different Graphs Available .....	65
<b>CHAPTER 8</b>	<b>Getting Recorded Data out</b> .....	67
	Retrieving Data from the Instrument.....	67
	Converting to ASCII Format.....	69

	Finish Operations.....	72
	Erasing Recorded Data .....	72
	Binary Data Files.....	73
<b>CHAPTER 9</b>	<b>Operational Concerns</b> .....	<b>75</b>
	My Data Fails to Look Right.....	75
	Correcting Data for Sound Speed Errors .....	75
	Boundaries and Sidelobes.....	76
	Grounding Problems.....	77
	Mooring Tilt.....	77
	Mooring Vibration .....	77
	Troubleshooting .....	77
	Simple Problems .....	77
	Problems Detecting the Instrument on the Serial Port.....	78
	Serial Loop-back Test.....	78
<b>CHAPTER 10</b>	<b>Maintenance</b> .....	<b>79</b>
	Preventive Maintenance .....	79
	Cleaning.....	79
	Antifouling.....	79
	Replacing the Desiccant .....	80
	Installing/ Changing Batteries.....	80
	Corrective Maintenance .....	81
<b>APPENDIX</b>	<b>Returning Aquadopp for Repair</b> .....	<b>83</b>





# CHAPTER 1

## Introduction

---



The Aquadopp profiler is available with a variety of head configurations.

Aquadopp is a registered trademark of Nortek AS

Thank you for purchasing a Nortek Aquadopp® Profiler. The Aquadopp Profiler has been designed to give you many years of safe, reliable service.

The Aquadopp Profiler measures the current profile in water using acoustic Doppler technology. It is designed for stationary applications and can be deployed on the bottom, on a mooring rig, on a buoy or on any other fixed structure. It is a complete instrument and includes all the parts required for a self contained deployment with data stored to an internal data logger. Typical applications include coastal studies, online monitoring and scientific studies in rivers, lakes, and channels.

The Aquadopp Profiler uses three acoustic beams slanted at 25° to accurately measure the current profile in a user selectable number of cells. The internal tilt and compass sensors tell the current direction and the high-resolution pressure sensor gives the depth—and the tidal elevation if the system is fixed mounted. The standard 9MB recorder and internal alkaline batteries are typically sufficient for a 2–4 month deployment.

Deployment times can be increased or sampling schemes intensified by expanding to 161MB memory and external lithium or even rechargeable batteries. Further expansion is available through the use of external battery canisters.

### Practical Use

One quick glance at the Aquadopp profiler tells you that it is a small and practical current profiler that is simple to deploy. It gives you the full current profile and it comes standard with all the trimmings such as a internal recorder, compass, tilt, pressure, temperature, software, cable, etc.

## Getting Started

### To get you up and running:

- 1 Before you start using the Aquadopp, please familiarize yourself with the Current Profiler by reading *Chapters 2, 3, and 4* of this user guide.
- 2 Perform reception control and functional test of the Aquadopp according to procedures in *Chapter 5*.
- 3 Start using the Aquadopp according to procedures in *Chapter 6*.
- 4 Perform regular maintenance according to procedures in *Chapter 10*

## Warranty

In order to stay up-to-date and receive news and tips from the factory you should register at our web site. Use the Internet and go to <http://www.nortek-as.com/newsletter.php>. Enter your name, e-mail address and topics of interest.

We also recommend our User Forum where you may post questions and discuss with other people in the oceanographic community. To get to the User Forum enter <http://www.nortek-as.com> and click on **Forum**. If you have no internet access or, if you—for any other reason—prefer traditional mail or telefax, you may fill in and return the registration part of the warranty sheet accompanying your Nortek product.

Nortek AS grants a one year limited warranty that extends to all parts and labour and covers any malfunction that is due to poor workmanship or due to errors in the manufacturing process. The warranty does not cover shortcomings that are due to design, nor does it cover any form of consequential damages as a result of errors in the measurements.

In the unlikely event of trouble with your Nortek product, first try to identify the problem by consulting the documentation accompanying your Nortek product. If you need further assistance when trying to identify the problem, please contact your local Nortek representative or the factory.

Please make sure you receive a Return Merchandise Authorization (RMA) *before* any product or module is returned. An RMA can be obtained using our e-mail address: [inquiry@nortek.no](mailto:inquiry@nortek.no) or our Fax No.: +47 6713 6770. See also the *Appendix*.

# CHAPTER 2

## Technical Specifications

---

### Water velocity measurement

<b>Acoustic frequency:</b>	0.4 MHz	0.6 MHz,	1.0 MHz,	2.0 MHz
<b>Maximum profiling range*:</b>	60–90 m	30–40 m	12–20 m	4–8 m
<b>Cell size:</b>	2–8 m	1–4 m	0.3–4 m	0.1–2 m
<b>Minimum blanking:</b>	1m	0.50 m	0.20 m	0.05 m
<b>Maximum number of cells:</b>	128			
<b>Velocity Range:</b>	±10m/s (call for extended range)			
<b>Accuracy:</b>	1% of measured value ±0.5 cm/s			
<b>Max. Sampling rate:</b>	1Hz			
<b>Velocity uncertainty:</b>	Consult software program			

\*) The Aquadopp profiler measures the current profile in a user specified number of cells from the instrument out to a maximum range that depends on the acoustic scattering conditions. The lower range should be expected with clear water and small cells and the higher range with large cells and acoustically turbid water.

### Echo intensity

<b>Sampling:</b>	Same as velocity sampling rate			
<b>Resolution:</b>	0.45 dB			
<b>Dynamic range:</b>	90 dB			

### Transducer

<b>Frequency:</b>	0.4 MHz	0.6MHz	1.0MHz	2.0MHz
<b>Number of beams:</b>	3	3	3	3
<b>Beam width:</b>	3.7°	3.0°	3.4°	1.7°

## Standard sensors

**Temperature sensor:** Thermistor embedded

**Range:**  $-4^{\circ}\text{C}$  to  $40^{\circ}\text{C}$

**Accuracy/resolution:**  $0.1^{\circ}\text{C}/0.01^{\circ}\text{C}$

**Time response:** 10 min

**Compass sensor:** Flux gate with liquid tilt

**Maximum tilt:**  $30^{\circ}$

**Accuracy/resolution:**  $2^{\circ}/0.1^{\circ}$

**Tilt sensor:** Liquid level

**Accuracy/resolution:**  $0.2^{\circ}/0.1^{\circ}$

**Up or down:** Automatic detect

**Pressure sensor:** Piezoresistive

**Range:** 0–100 m (standard)

**Accuracy/resolution:** 0.25%/0.005% of full scale

## Analogue inputs

**Number of channels:** 2

**Voltage supply:** Battery voltage. Hardware can be modified to provide 5 V or 12 V

**Voltage input:** 0–5 V

**Resolution:** 16 bit A/D

## Serial data communication

**I/O:** RS232, RS422. Software supports most commercially available USB–RS232 converters

**Baud rate:** 300–115200 (user setting)

## Internal recording

**Capacity:** 9MB, expandable to 33, 89, or 161MB

**Data record:** 32 bytes +  $9 \times N_{\text{CELLS}}$

**Mode:** Stop when full (default) or wrap mode

## Software “AquaPro”

**Operating system:** Windows®2000, Windows®XP

**Functions:** Deployment planning, data retrieval, ASCII conversion, online data collection, and graphical display

## Power

**DC Input:** 9–16 VDC

**Max average consumption at 1Hz:** 0.2–1.5 W

**Sleep consumption:** 0.0013 W

**Transmit power:** 0.3–20 W, 4 adjustable levels

**Internal batteries**

**Type/capacity:** 18 AA Alkaline cells/50Wh

**New battery voltage:** 13.5 VDC

**Duration (10-minute avg.):** 80 days for 2 MHz, 0.5 m cells

**Duration (10-minute avg.):** 50 days for 1 MHz, 1.0 m cells

**Duration (10-minute avg.):** 40 days for 600 kHz, 2.0 m cells

**Duration (10-minute avg.):** 20 days for 400 kHz, 2.5 m cells

Exact battery consumption and velocity uncertainty are complex functions of the deployment configuration. Please consult the AquaPro software for more exact predictions.

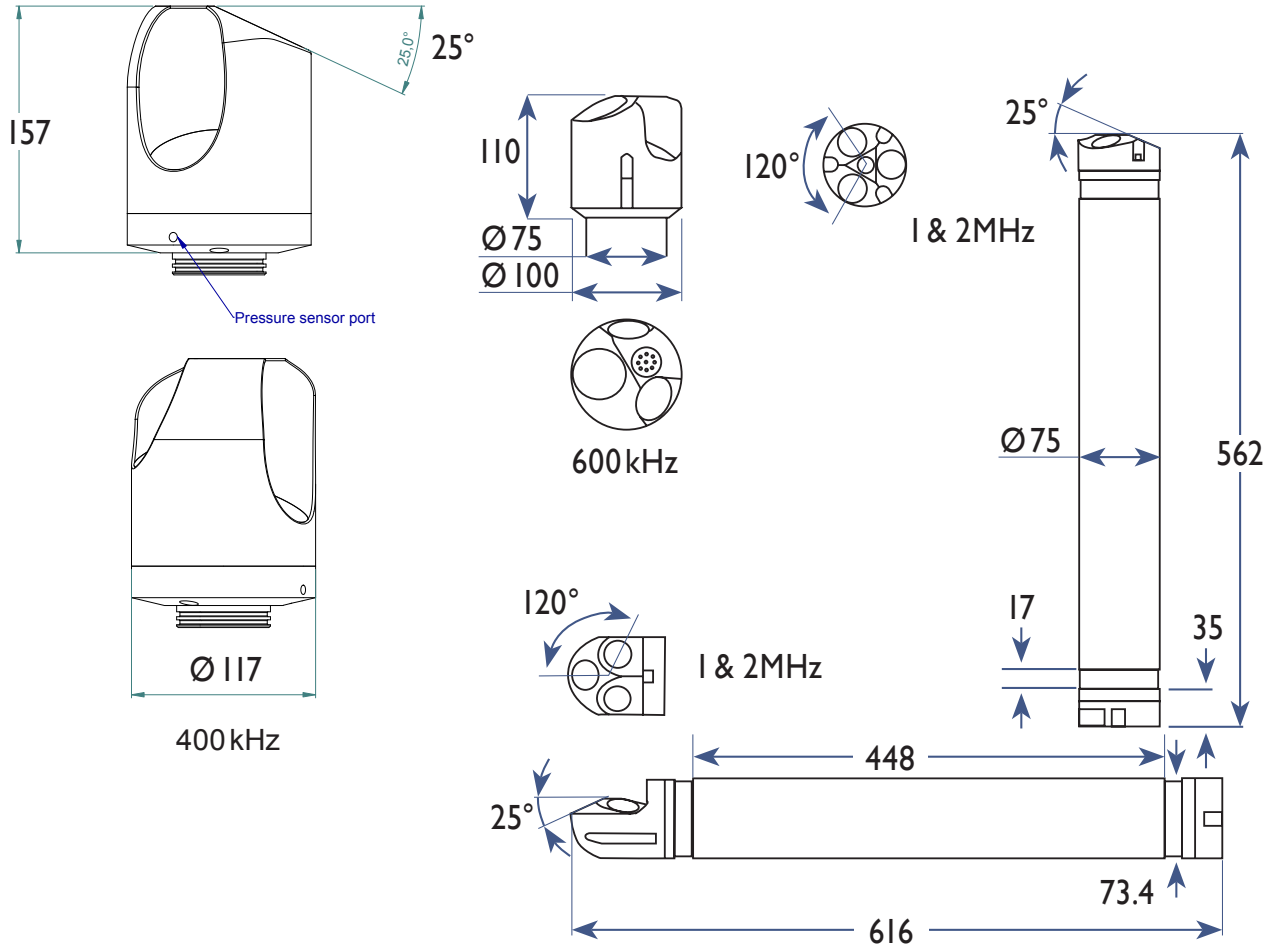

All dimensions are in mm unless indicated otherwise

## Dimensions

**Weight in air:** 2.4 kg / 2.6 kg (0.6 MHz) / 3.7 kg (0.4 MHz) with alkaline batteries

**Length:** See drawing on previous page

**Diameter:** See drawing on previous page

## Materials

**Standard:** Delrin and polyurethane plastics with titanium screws

## Connectors

**Bulkhead (Impulse):** MCBH-8-FS

**Cable:** PMCIL-8-MP on 10-m polyurethane cable

## Environmental

**Operating temperature:**  $-5^{\circ}\text{C}$  to  $35^{\circ}\text{C}$

**Storage temperature:**  $-20^{\circ}\text{C}$  to  $45^{\circ}\text{C}$

**Shock and vibration:** IEC 721-3-2

**Shallow water rating:** 300 m. This applies to all parts except the pressure sensor. The pressure sensor can withstand a max depth of 1.5 times its rating. Depending on the pressure sensor ordered, this may be the limiting factor determining the maximum deployment depth permitted.

## Options

**Batteries:** Lithium, Li-Io rechargeable

**External batteries:** 200 Wh, 540 Wh or 1080 Wh alkaline

**Bulkhead connectors:** Titanium instead of bronze

**Transducer head:** Right angle head for 1 or 2 MHz. Special configurations available on request.

# CHAPTER 3

## Technical Description

---



**Above:** The 1 MHz and the 2 MHz profilers are available with the two leftmost head configurations, while the 600 kHz profiler (to the right) has a slightly larger head.

**Below:** The 400 kHz version has an even larger head.

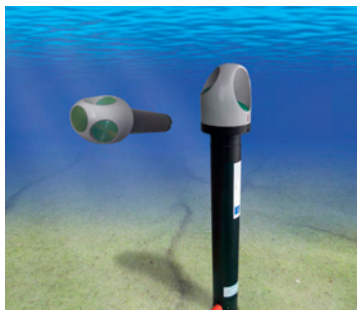

The illustration shows the Aquadopp Profiler variants. The 400 kHz model has a much larger head and the 600 kHz model has a slightly larger head than the 1 MHz and the 2 MHz versions.

### Aquadopp Profiler Components

The sensor head contains three acoustic transducers, the tilt sensor, the temperature sensor, and the pressure sensor:

- The **Tilt sensor** is mounted on a small separate pcb (printed circuit board) attached to the head, inside the case. The tilt sensor orientation is set in accordance with the system orientation during normal operation. The standard Aquadopp is designed for vertical orientation. However, tilt sensors in heads designed for horizontal orientations will be mounted so they fit this type of orientation. All Aquadopp Profilers can be used upside down (relative to the designed orientation) without problems.
- The **Temperature sensor** is standard on all Aquadopp Profilers and is mounted inside the sensor head.
- The **Pressure sensor** is moulded inside the Aquadopp Profiler sensor head.

Other components include:

- **Electronics module.** The electronics consist of a board holding the power transmitter, analogue and digital signal processing circuitry, power conditioning module, and a 9 MB data recorder.
- **Compass.** The built-in magnetometer measures the earth's magnetic field. Combined with the tilt sensor on the head, this forms a compass, which enables the Aquadopp Profiler to obtain the heading. These data enables the Aquadopp Profiler to convert velocity measurements to Earth coordinates. Observe that

The main parts of an Aquadopp Profiler

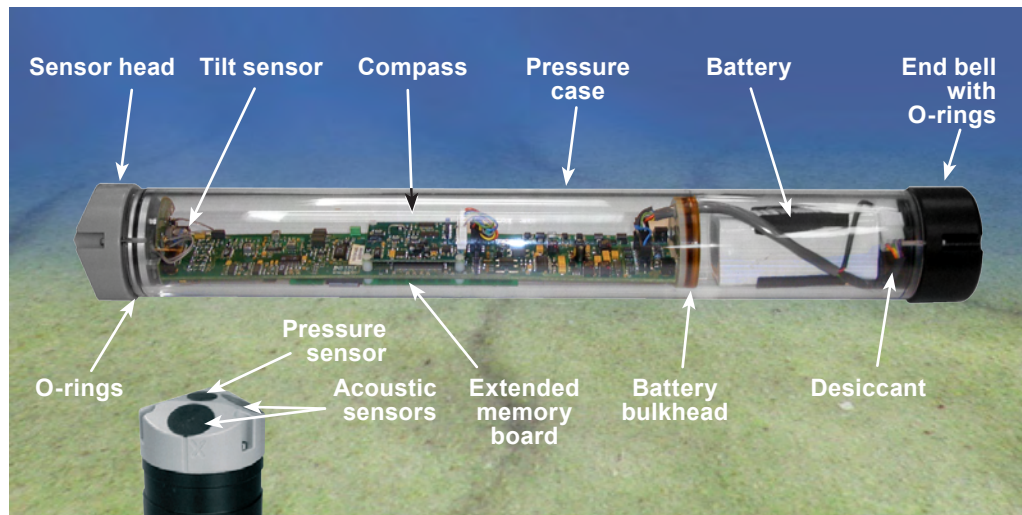

without a magnetometer, the Aquadopp Profiler still measures the tilt.

**Tip!** NORTEK alkaline battery packs start life at a voltage of 13.5VDC or higher. The voltage of alkaline batteries falls quickly at the beginning, slowly during most of its life, then again quickly at the end. Thus a 13.5VDC battery pack will spend the largest part of its life somewhere in a voltage range of 10.5–12.5VDC.

- **Internal battery pack.** The internal battery pack is located inside the pressure case, and enables autonomous deployments of up to a year. It also provides backup power in the event of failure of the external supply. Standard alkaline battery packs use 18 AA cell batteries at a nominal starting voltage of 13.5 VDC.
- **Power & communication cable.** The power and communication cable is connected to the external connector. The cable supplies external DC power (9–16 V) and connects an external computer to the Aquadopp Profiler for two-way serial communication.

## Cable Wiring

The Aquadopp comes standard with an 8-conductor RS 232 cable, but it can be ordered with an 8-conductor cable for use with RS 422 communication. The tables list the pin assignments for cable wiring options offered.

The Aquadopp power and battery lines are diode protected, so you don't have to worry about wiring the Aquadopp power backwards – this will not damage your instrument.

## Power Requirements Using RS 422

RS 422 power requirements are higher than those of RS 232, and harder to predict. RS 422 increases sleep power consumption to at least 60mW and it increases operational power consumption by 60–250mW, depending on how the RS 232/RS 422 converter is terminated. Since RS 422 is normally used in real time operations, you may supply the additional required power from an external power source.

**Caution!** Be sure to use *silicone spray* and not *silicone grease* on the dummy plugs and the cables. The use of silicone grease on these may cause permanent damage to the system! Silicone grease should be applied to the O-rings only.

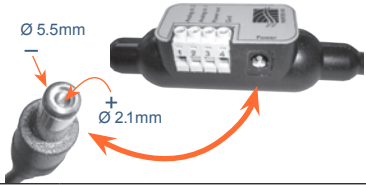

**Wiring of RS232 cable with analogue input**

Underwater connector				Termination	
Pin No.	Wire colour	Purpose		Pins	Description
3	black	RS232 Tx	twisted pair	2	
4	white	RS232 Rx		3	
5	black	RS232 Gnd	twisted pair	5	
6	white/purple	Power output			
7	black	Analogue ch 2	twisted pair		
8	white/orange	Analogue ch 1			
1	black	Power Gnd	twisted pair		
2	white	Power +			
screen	bare	Gnd	ground		3 bare wires for Gnd, connected internally to power Gnd

**Wiring of 8-conductor cable for RS422 communication**

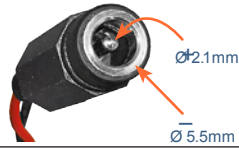
Underwater connector				Termination	
Pin No.	Wire colour	Purpose		Pins	Description
3	black	RS422 Tx+	twisted pair	7	
4	white	RS422 Tx-		2	
7	black	RS422 Rx+	twisted pair	8	
8	white/purple	RS422 Rx-		3	
5	black	Synch. out	twisted pair		
6	white/purple	Synch in			
1	black	Power Gnd	twisted pair		
2	red	Power +			
screen	bare	Power Gnd	ground		3 bare wires for Gnd, connected internally to power Gnd

**End bell and plug**



**Note!** Tx and Rx refers to the Aquadopp and not to the PC!

**Caution!** Be sure to use *silicone spray* and not *silicone grease* on the dummy plugs and the cables. The use of silicone grease on these may cause permanent damage to the system! Silicone grease should be applied to the O-rings only.



# CHAPTER 4

## Functional Description

---

This chapter briefly describes some of the underlying principles that control the operation and application of the Aquadopp Profiler.

### Modes of Operation

The Aquadopp Profiler has three different modes of operation:

- **Command mode.** An Aquadopp Profiler in *Command mode* is powered up and ready to accept your instructions. If no commands are received for approximately five minutes, it will automatically power down and enter *Sleep* or *Power down mode*.

Most commands cannot be sent directly to the Aquadopp Profiler. These commands include i.a. the deployment setup commands. Instead, you must enter commands through the AquaPro software. The AquaPro software and hardware interact with each other using low-level binary data structures. This approach simplifies the design of the AquaPro hardware and increases its overall reliability.

- **Data acquisition mode.** The Aquadopp Profiler enters the *Data acquisition mode* when you click any of the **Start** commands (i.e. **Start Recorder Deployment** in the AquaPro software). When you initiate a deployment sequence, the software converts your setup parameters into binary structures, downloads the structures to the Aquadopp Profiler and tells it to start data collection.

To get the instrument out of *Data acquisition mode*, use one of the **Stop** commands in the AquaPro software. You might notice that sending a break to an Aquadopp Profiler in *Data acquisition mode* will produce a response from the instrument, but the data acquisition itself will be unaffected. The purpose

**Tip!** If you set the Aquadopp Profiler to collect data, remove the power, then reapply power later, the Aquadopp Profiler will immediately resume data collection. Remember that the internal clock may have lost the correct time of day.

**Basic concepts.** The Aquadopp Profiler measures the current in a set of cells along each beam to obtain the current profiles as shown in this simplified drawing.

For clarity, only five cells are shown for each beam. The fact that the cells overlap each other has also been left out.

Theoretically, there can be up to 128 cells per beam, but in real applications this will be limited by the range of the beams and the highest resolution (i.e. smallest cell size) permissible.

The **blanking** is the time during which no measurement takes place, essentially to give the transducers time to settle after having emitted a pulse (the transducers are used as both transmitters and receivers).

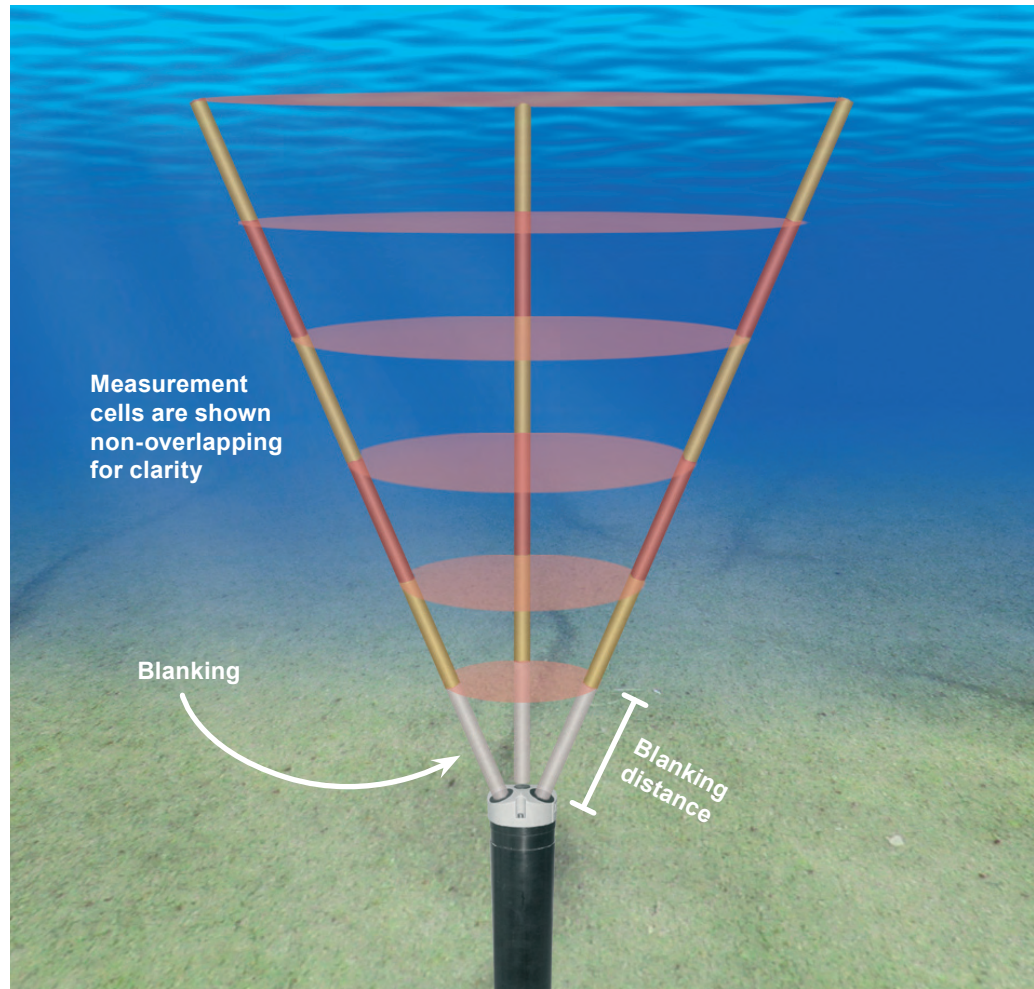

of this design is to protect the system from stopping after an accidental break. To bring the acquisition to a halt, you will need to confirm the break.

People using the Aquadopp Profiler with an external data logger (or similar devices) may want to know that if the measurement has been started using the low level command **AD** in lieu of **ST**, a confirmation will not be needed to halt the system after a break.

This and other features of the low level command control system is described in the *Paradopp Interface manual*, which is available separately – contact the factory for details.

- **Power down mode.** The *Power down mode* saves power during deployments and prevents your battery from dissipating between deployments. The Aquadopp Profiler automatically powers down from *Command mode* after about five minutes of inactivity.

To conserve your battery when the Aquadopp Profiler is on the shelf, be sure it is not in *Data acquisition mode*. Stop data collection using one of the **Stop** buttons before you store your Aquadopp.

**The cells overlap.** The Aquadopp Profiler applies triangular weighting to each measurement cell as indicated along the beam.

The baseline of the weighting function is twice the nominal cell size. About 75% of the acoustic return energy comes from the nominal sampling volume.

Note how the cells overlap each other along the beam.

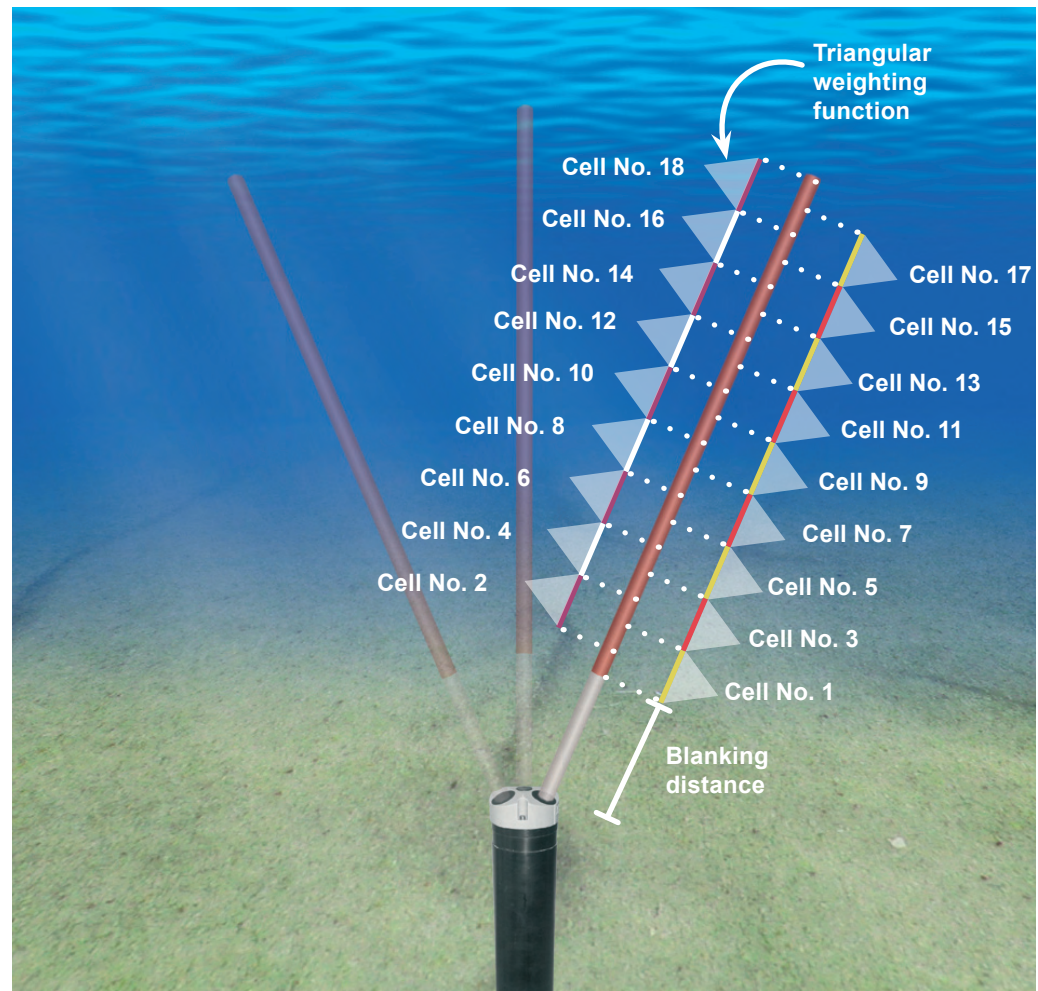

## Using the Doppler Effect

**Tip!** A tutorial providing insight in Doppler measurement basics can be found at <http://www.nortekusa.com/principles.html>

You hear the Doppler effect whenever a train passes by—the change in pitch you hear tells you how fast the train is moving. The Aquadopp Profiler uses the Doppler effect to measure current velocity by transmitting a short pulse of sound, listening to its echo and measuring the change in pitch or frequency of the echo.

There are many ways to measure the Doppler effect, each with its own advantages and drawbacks. Nortek implements a narrow band auto covariance method, because this has been established as robust, reliable and accurate.

Sound does not reflect from the water itself, but rather from particles suspended in the water. These particles are typically zoo plankton or suspended sediment. Long experience with Doppler current sensors tells us that the small particles the Aquadopp Profiler sees move on average at the same speed as the water—the velocity it measures is the velocity of the water.

## Doppler Beams

Doppler current sensors use large transducers (relative to the wavelength of the sound) to obtain narrow acoustic beams. For example, the 2 MHz Aquadopp Profiler has a beam width of 1.7°. Narrow beams are essential for obtaining good data.

Each beam measures velocity parallel to the beam and does not sense the velocity perpendicular to the beam at all. The Aquadopp Profiler senses the full 3D velocity with three beams, all pointing in different directions. If you assume the flow is uniform across the three beams, simple trigonometry is sufficient to compute the velocity in any direction. The Aquadopp Profiler will still provide a good measurement in a non-uniform flow if the horizontal variations are linear.

The measurement cell is shaped like a triangle (as indicated in the Fig. on the previous page). The maximum extent of the weighting function is twice the length of the transmit pulse.

## Coordinate Systems

The Aquadopp Profiler measures velocity components parallel to its three beams, i.e. in **Beam** coordinates, but it reports data in **East**, **North** and **Up** or **ENU** coordinates. To get to ENU components, it first converts the data to XYZ coordinates, an orthogonal coordinate system relative to the Aquadopp Profiler. The instrument then uses its magnetometer and tilt measurements to convert this velocity to components relative to the earth, or ENU coordinates.

### The coordinate systems are defined as follows:

- In **Beam** coordinates, a positive velocity along beam 1 goes in the direction towards which the beam 1 points. See the right Fig for beam definitions.
- In **XYZ** coordinates, a positive velocity in the X-direction goes in the direction of the X-axis arrow.
- In **ENU** coordinates, a positive east velocity goes toward east.

## Attitude Correction

Typical moorings allow the Aquadopp Profiler to tilt and rotate freely. It measures tilt and heading and uses this compass information to convert the data to true earth coordinates. How often the instrument reads the tilt and heading depends on the deployment setup used.

As is explained in *Chapter 6—Operation*, the AquaPro software allows you to either use one of a series of predefined deployment setups, or to create your own setup.

The predefined setups provide a compass-reading frequency reflecting the application. For example, in a near-surface mooring the instrument will read the magnetometer and the tilt more often than it would on a fixed bottom mount.

**Beam direction.** In beam coordinates, a positive velocity along beam 1 goes in the direction towards which the beam 1 points.



**XYZ direction.** The Aquadopp Profiler XYZ direction varies with the head configuration as shown here. The leftmost and the rightmost units both have an X engraved to show the X-direction. See also *Coordinate Systems* for details.

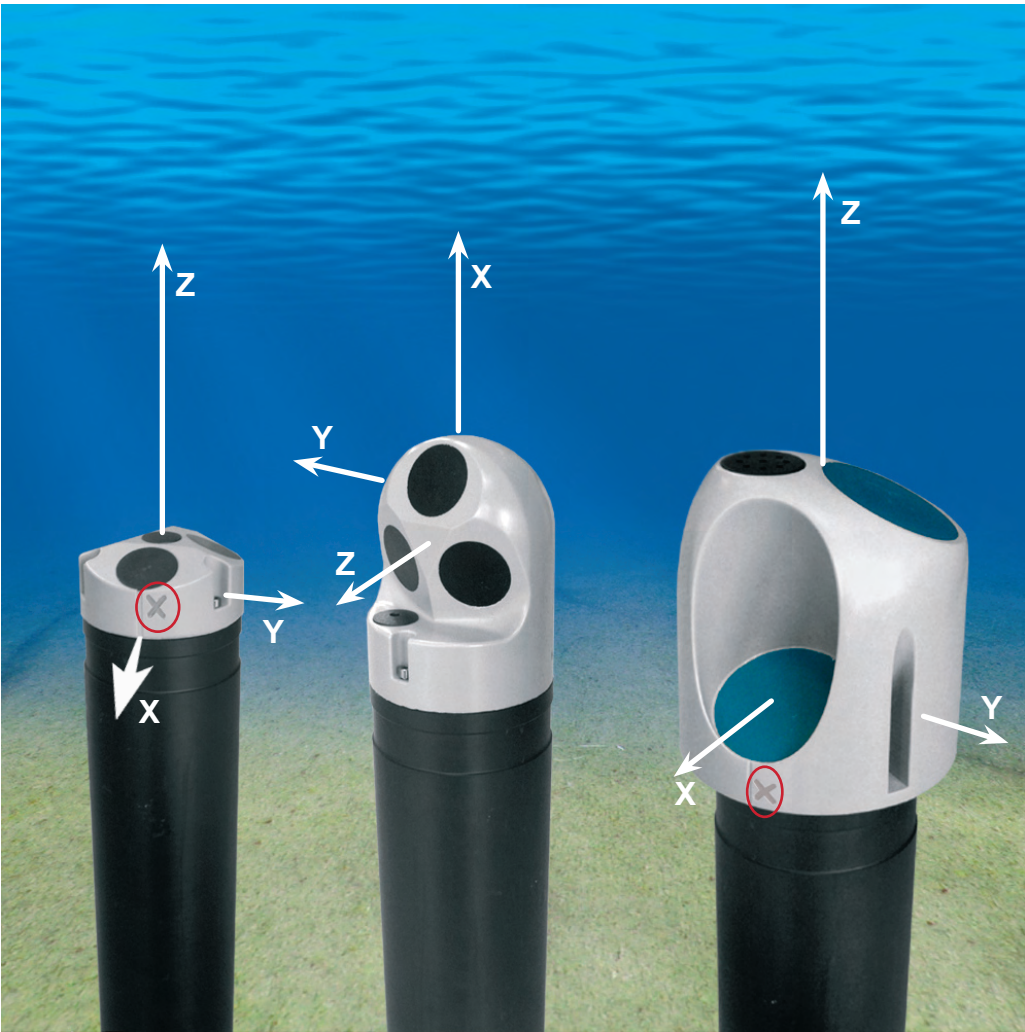

Because the magnetometer uses energy, the Aquadopp Profiler reads heading only as often as it needs to. This trade-off between power consumption and the need for accuracy is well taken care of in the predefined deployment setups. We therefore recommend that you stick to the predefined compass update rates (as they appear when you select a deployment environment) when creating your own deployment setup, unless you have good reasons for doing otherwise.

**Note:** The AquaPro software predicts the instrumental error only. In many situations, environmental turbulence will dominate the short term velocity fluctuations.

## Velocity Uncertainty

The recorded velocity is an average of many velocity estimates (called *pings*). The uncertainty of each ping is dominated by the *short-term error*. We reduce the measurement uncertainty by averaging many pings together. There is a limit to how much you can reduce your uncertainty. We call this limit the *long-term bias*.

The long-term bias depends on internal signal processing, the filters, and the beam geometry. The long-term bias in the Aquadopp Profiler is typically a fraction of 1 cm/s. The AquaPro software predicts errors based on the short-term error of a single ping and the number of pings averaged together. The short term error of a single ping depends on the size of the transmit pulse and the measurement volume, and it depends on the beam geometry. Velocity components parallel to the acoustic beams will have smaller short-term errors than velocity components at a steep angle relative to the acoustic beams. Averaging multiple pings reduces errors according to the formula:

$$\sigma_{v_{\text{mean}}} = \frac{\sigma_{v_{\text{ping}}}}{\sqrt{N}}$$

in which  $\sigma$  is the standard deviation and  $N$  is the number pings you average together.

In turbulent flow such as boundary layers, your data collection strategy should take into account the nature and the time scales of the environmental fluctuations. A rough rule of thumb in boundary layers is that the RMS turbulent velocity is 10% of the mean velocity. If, for example, your mean velocity is 1 m/s, you could estimate turbulent fluctuations to be 10 cm/s. Obtaining 1 cm/s RMS uncertainty would require at least 100 pings.

## Measuring Waves

**Tip!** Tutorial articles on wave measurements using the PUV method can be found at <http://www.nortekusa.com/principles/Waves.html#PUV>

The Aquadopp Profiler may also be used to measure waves using the PUV method. However, it is important to remember that the Aquadopp Profiler collects raw wave data. Therefore the data, by inspection, may not be entirely meaningful. This raw data must go through a processing step before it can be used to inter-



pret the waves on the surface. The processing will lead to classic wave estimates for height, period, and direction. Unlike the current profile estimates the wave processing is quite complex. The Nortek software programs **QuickWave** or **Storm** (available separately) can be used for this post processing.

The Aquadopp Profiler measures the pressure and two horizontal velocity components when used in wave mode.

The data record of the raw signal will not provide a clear view of the wave environment on the surface. For instance, the pressure record is an attenuated version of the free surface. The attenuation depends upon the Aquadopp Profiler's deployment depth as well as the surface wave frequencies. Therefore this data record is not going to be particularly useful until processing is performed. This is similarly true of the orbital velocity measurements. In fact, the orbital velocities will often appear noisy, and a sinusoidal wave pattern can sometimes be difficult to observe when waves are short in period.



# CHAPTER 5

## Preparing the Instrumentation

We strongly advise that you check the shipment upon arrival. The below photo shows the contents of a standard shipment. The type of communication cable supplied depends on the type of communication (RS 232 or RS 422) ordered.

The contents of a standard shipment. Every effort has been made to ensure that the shipment is in accordance with your order. However, as a precaution we recommend that you examine the shipment carefully before heading to the deployment site. In the unlikely event of discrepancies, kindly report these to the factory immediately.



## Connecting the Battery



Use a CRT monitor and not an LCD monitor when degaussing alkaline batteries.

The Aquadopp Profiler is shipped with a battery pack installed in the pressure case, but disconnected.

As a general precaution, alkaline batteries should always be degaussed before you use them in your instruments—you can do this yourself by placing the padded end of the battery up against the centre of your PC monitor (CRTs, not LCD screens) and using the monitor's degaussing function. The purpose of this is to minimise any effect on the compass.

Always be sure to include desiccant in the pressure case. Humid air, trapped inside the canister can condense enough water to damage the electrical circuitry when the instrument is deployed in cold waters.

### To connect the battery pack:

- 1 Remove the four screws (1) and washers holding the end cap to the pressure case and remove the end cap.
- 2 Pull the battery out of the pressure case (2).
- 3 Connect the battery to the 2-pin connector (3) and re-insert.
- 4 Insert the end cap to the pressure case and mount the four screws and washers. Tighten the screws carefully to avoid damaging the threads in the pressure case. Tighten the screws only until the end-cap touches the pressure case (typically a torque of 2–3 Nm) and you can just feel that they are seated. Keep in mind that ocean pressure holds the end cap in tightly—all the screws have to do is to seat the o-rings properly and keep the end cap from falling out when the system is above water.

Connecting the batteries

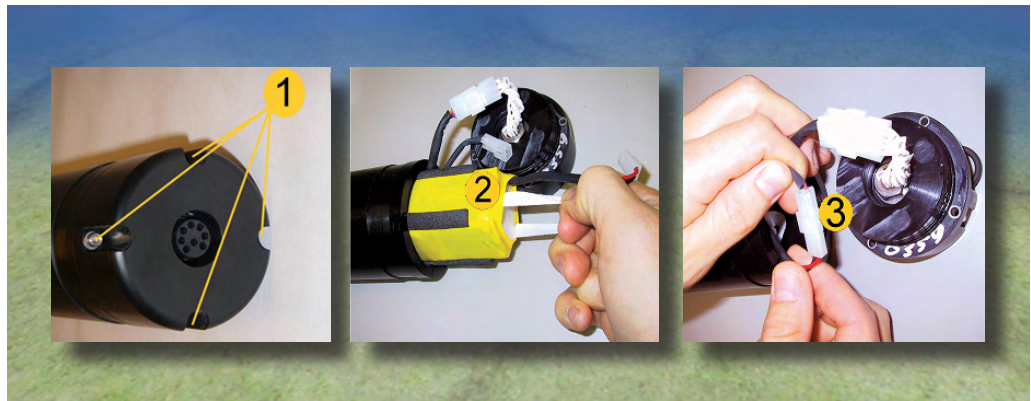

## Installing the AquaPro software on a PC

The AquaPro CD contains everything you need to install and run the Nortek AquaPro application and has been designed for computers running Microsoft® Windows® 2000 and Windows® XP. You must install the application from the CD onto your hard disk; you cannot run the program from the CD.

### Installing the program:

- 1 Insert the AquaPro CD. Browse to the AquaPro program folder and locate the file **Setup.exe**.
- 2 Double-click **Setup.exe** and follow the on-screen instructions.

## Running the AquaPro Program

You start the Nortek AquaPro just as you would start any software application:

- Click **Start > Programs > Nortek > AquaPro**.

If you installed the program in a folder different from the default setting (default folder name is **Nortek**), substitute accordingly in the above setting.

## Resources Available to Get You Started

The following resources are at your disposal to get you up and going:

- This manual, which also is accessible from within the program.
- The on-line help, which also contains a context sensitive help section.
- Nortek on the world wide web for updates and technical support (see details on page 4 of this user guide).
- The Nortek Forum (see details on page 4 of this user guide).

## Running a Functionality Test

To run a functionality test:

- 1 Plug in the AC adaptor and connect the Aquadopp to the PC serial port. Start the AquaPro program.
- 2 Select **Serial Port** from the **Communication** menu to specify the port number to use:

Setting up the serial communication.

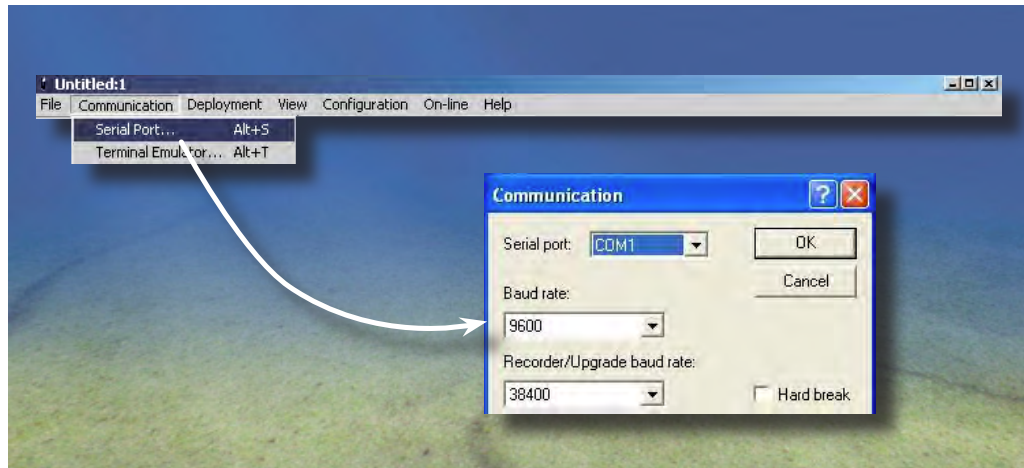

- 3 Accept the default baud rate settings (9600 baud), which is also the default instrument baud rate.
- 4 Check the instrument communication and verify that the instrument is alive by activating the **Terminal Emulator** window and press the **Send Break** button to send a BREAK signal over the serial port.

The terminal emulator

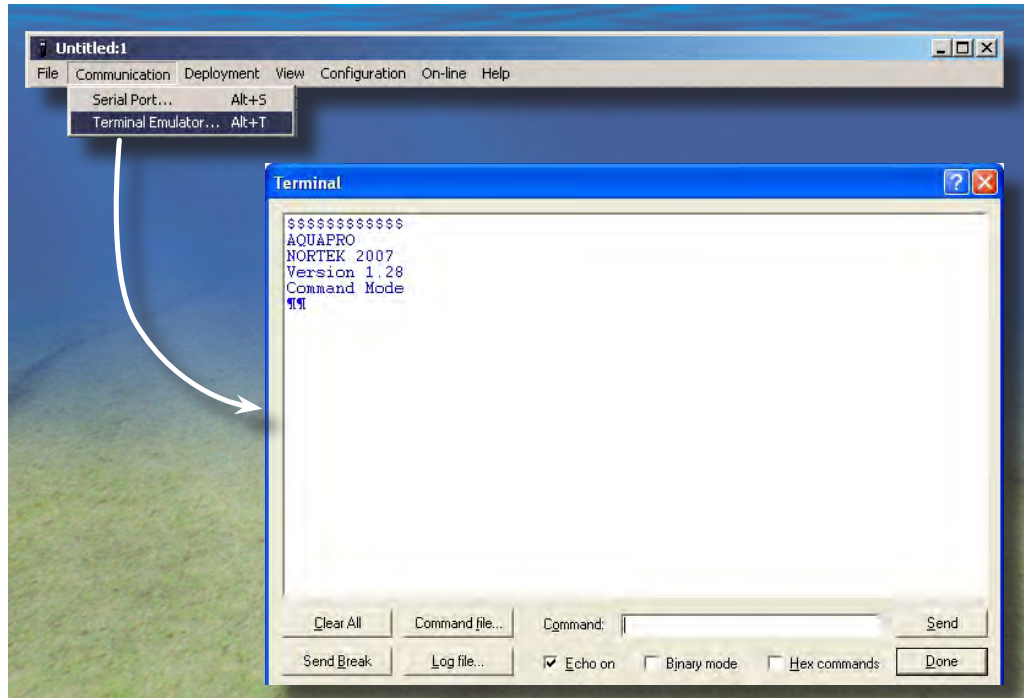

A break causes the instrument to report an identification string (see also side bar discussing the Break command) unless it is in *Data acquisition mode* when the break is received. In the latter case the instrument will respond with

Confirm?

## A few words on the Break command

The **Break** is used to interrupt the instruments regardless of what mode they are in. It is frequently used in the communication with the instrument.

Traditionally, sending a break was done by holding the transmit line high on the serial line for a period of 500ms. This is what we refer to as **hard break**. This works fine if you have a direct connection between your PC and the instrument. But once you use something else, for example a modem, you may get into trouble. The problem is that different types of modems handle hard breaks in their own way. Certain GSM modems will, for example, accept a 500 ms hard break on the input, but they will only output a 100 ms hard break, which will may not be accepted as a break in the instrument.

To cope with problems like these, our instruments therefore offer soft break as default. The soft break consists entirely of characters, so it can be used with any device capable of RS232 or RS422 communication.

With two types of break and one version of the communication software you will get communication problems if the software is set up with the wrong type of break.

The easiest way to circumvent this problem is to use the **auto detection feature** in the software. Make sure you have chosen the correct serial port and press the **Stop Data Collection** button on the toolbar. The software will then find the correct communication baud rate and break type for you.

and expect the **MC** command to accept the break and suspend its ongoing activities. When on the other hand this is done from the AquaPro software the instrument will prompt you to confirm your intention of suspending its activities.

Close the terminal emulator upon successful communication. If unsuccessful, check battery, cabling, and COM port.

- 5 Check the noise level of the instrument by selecting **Deployment > Planning > Use existing** to produce the below dialogue box. Set the **Profile interval (s)** to 1 second as shown, and click **OK**. Then click "**Online > Start Data Collection**" or the corresponding icon.

Setting the profile interval to 1 second

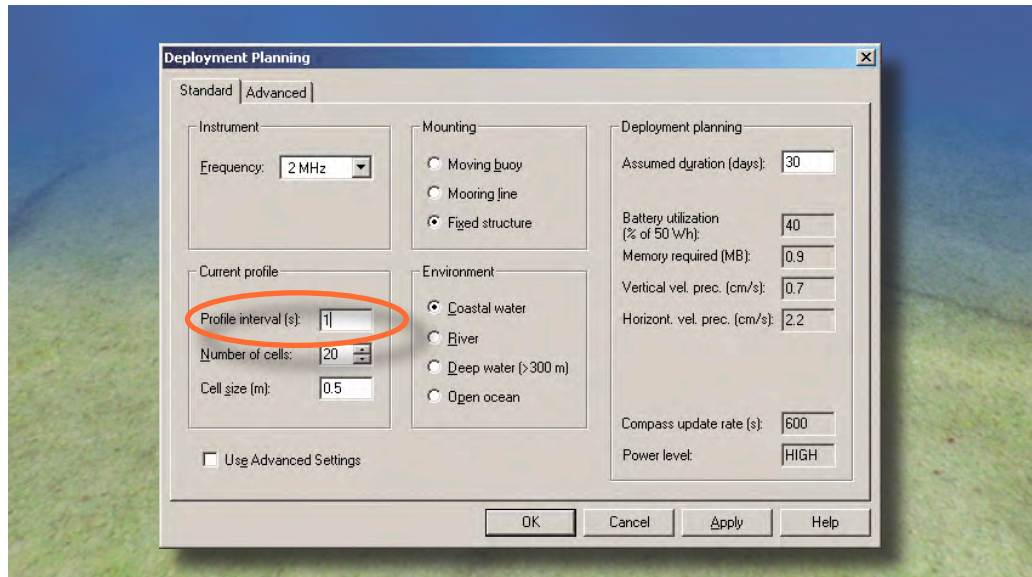

Keep the Aquadopp Profiler out of water. This pinging in air should produce a signal strength (**Amplitude**) of 20–30 counts (2 MHz version), 25–35 counts (1 MHz version), 30–40 counts (600 kHz version) and 20–40 counts (400 kHz version). The signal level thus obtained is called the noise floor. When the instrument pings in air, the velocity measurements will be nothing but noise.

Screenshot taken from a PC running Windows® XP, showing pinging in air (and consequently the noise floor). If you haven't set the date in your Aquadopp yet, it will show a date from the year 2000.

Be sure to select **Amplitude** in the bottom line of the display as indicated in the Fig.

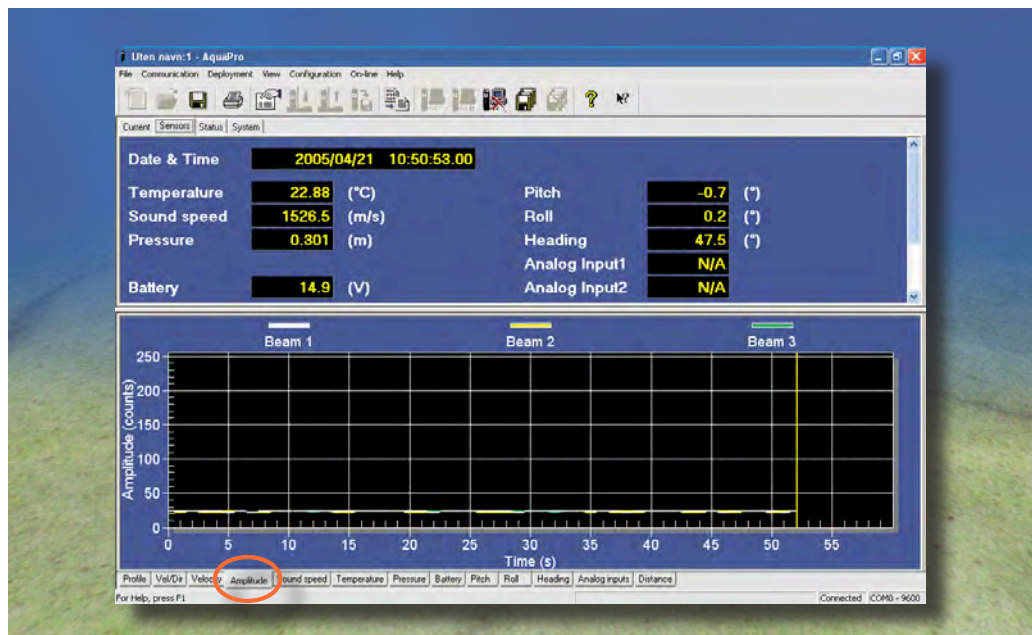

Put the instrument in a bucket of water and observe the signal strength and the velocity. The signal strength should rise noticeably (the actual level depends on the size, shape and material of the bucket), and the velocity data should appear less noisy.



## 6 Check sensor readings:

- Tilt and rotate the Aquadopp Profiler to verify that the readings make sense (see *Verifying the Internal Sensors* later in this chapter for details).
- Check the temperature as measured by the Aquadopp Profiler. This should be close to your room temperature, assuming the Aquadopp Profiler has been in the room for a while. In case of incorrect temperature measurements. You may have to correct this. (see *Verifying the Internal Sensors* later in this chapter for details).
- Calibrate the compass, if applicable. This is particularly important to do if the instrument is to be deployed near magnetic structures (typically frames or other structures containing magnetic material. Observe that the compass calibration must take place in-situ (i.e. mounted in the frame) to take the frame's magnetic effects into account. The procedure is described in *Verifying the Internal Sensors* later in this chapter.
- Pressure should be near zero. Check the pressure sensor in a bucket 50 cm deep, or put your mouth over the pressure sensor and blow to create a pressure of around 50–150 cm. You may want to insert a pressure offset to align the depth indication to other measurement gear used or to compensate for the ambient pressure. More on this is found in *Verifying the Internal Sensors* later in this chapter.

**If the Pressure Sensor Seems to Fail.** If you are running older versions (prior to version 1.24) of AquaPro, you may experience that the pressure sensor output zero at all times.

This may typically take place if the ambient pressure by the time of testing is significantly lower than it was by the time the pressure sensor was calibrated.

Internally, the instrument will note that the pressure now is negative and that will be reported as being zero (negative values are always reported as zero).

To circumvent this (for AquaPro versions prior to v. 1.24 ) you should add 10m as a pressure offset (see *Verifying the Internal Sensors* later in this chapter) before submerging. The AquaPro software will then report a positive pressure value and you will be able to confirm that the pressure changes accordingly as you submerge the transducer head.

From AquaPro v. 1.24 and onwards, this is taken care of internally. If a negative pressure is detected, the AquaPro itself adds an offset to the pressure and a second attempt is made automatically. As a user you will then see that the pressure increases correctly as the transducer head is submerged.

- Battery voltage shall be greater than 13VDC (new battery).

**Note:** If you leave the Aquadopp Profiler collecting data, it will continue to run until the batteries are dead. Always make sure to stop data collection when testing is complete. This puts the Aquadopp into command mode and it will then enter into a sleep state (the lowest possible power) after 5 minutes of inactivity.

## Test the Recorder Function

You can test the recorder with the same setup as the above. Do as follows:

- 1 Start data collection with **Online** followed by **Start With Recorder**.
- 2 Write a name to use for the file you will record internally.
- 3 After a few minutes, stop the data collection.
- 4 Retrieve your data by clicking **Deployment > Retrieve Data**.
- 5 Convert it to ASCII by clicking **Deployment > Data Conversion**.
- 6 Review the collected data with an ASCII text editor (i.e. Notepad).

## Starting with an Empty Memory

To erase the Aquadopp Profiler's contents of data:

- 1 Make sure that any data you want to retain are transferred to your computer (if applicable) and that the data is in good shape.
- 2 Click **Deployment > Erase Recorder**.

## Verifying the Internal Sensors

The Aquadopp Profiler has four sensors that should be checked regularly to verify their performance. These are the tilt sensor, the temperature sensor, the pressure sensor, and the compass. It is of great importance to check and calibrate the compass. The compass is sensitive to all magnetic fields, not only the earth's. Hence magnetic material used in the mooring may bias the compass readings significantly.

### Calibrating the Temperature Sensor

The temperature sensor is calibrated using a very accurate temperature reference source before the instrument leaves the factory. Hence, we recommend that you start by checking the temperature sensor's performance by comparing its reading to that of a precision thermometer. If a significant deviation is revealed, you should consider to proceed as described below.

To calibrate the temperature sensor:

- 1 Make sure the Aquadopp Profiler is connected to the computer and let it be exposed to a constant temperature for more than 15 minutes to stabilize the temperature readings from the instrument.

- 2 Click **Online > Temperature Calibration**
- 3 Use a thermometer with sufficient precision for your task to read the ambient temperature and key in this temperature in the Aquadopp dialogue box.
- 4 Follow the online instructions.

**Temperature calibration.** Click **On-line > Temperature calibration** to produce this display and enter the ambient temperature. Make sure the Aquadopp temperature readings have stabilized – see text for details.

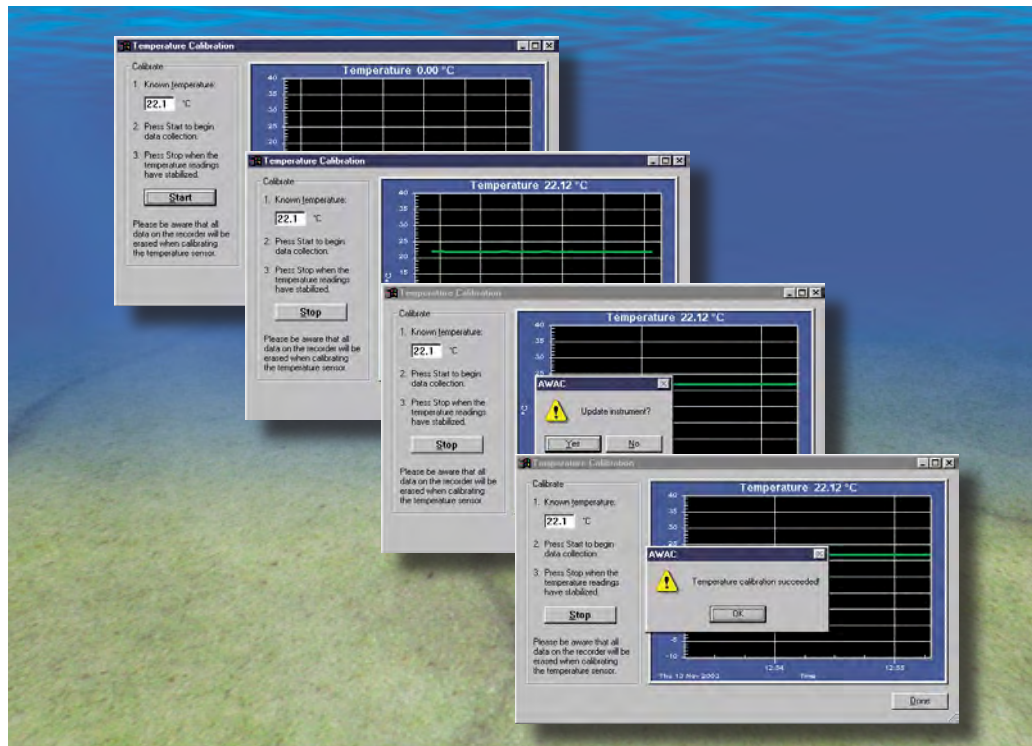

## Verifying the Tilt Sensor

To verify the tilt sensor:

- 1 While the Aquadopp Profiler is connected to the computer, place it level on a flat surface.
- 2 In the main screen inspect the heading, pitch, and roll readings.

**Tilt sensor verification.** Click the **Sensors** tab in the numerical tab part of the main screen and verify that the tilt readings make sense. In case of significant deviations, contact the factory.



## Setting the Pressure Sensor Offset

To calibrate the pressure sensor:

- 1 Have the Aquadopp Profiler connected to the computer and submerge the Aquadopp Profiler in water.
- 2 Click **On-line > Set Pressure Offset** and key in the depth in m. If you want to introduce an offset to e.g. use a common reference for your entire instrumentation on a deployment site. Note that the pressure sensor will not output negative values, and we recommend that you give the pressure sensor a positive offset.

**Tip!** See also *Running a Functionality Check – item 6*, in this chapter of the manual.

The dialogue box for setting the pressure offset – see text for more. Observe that atmospheric changes can vary the depth reading as much as 0.3 m!

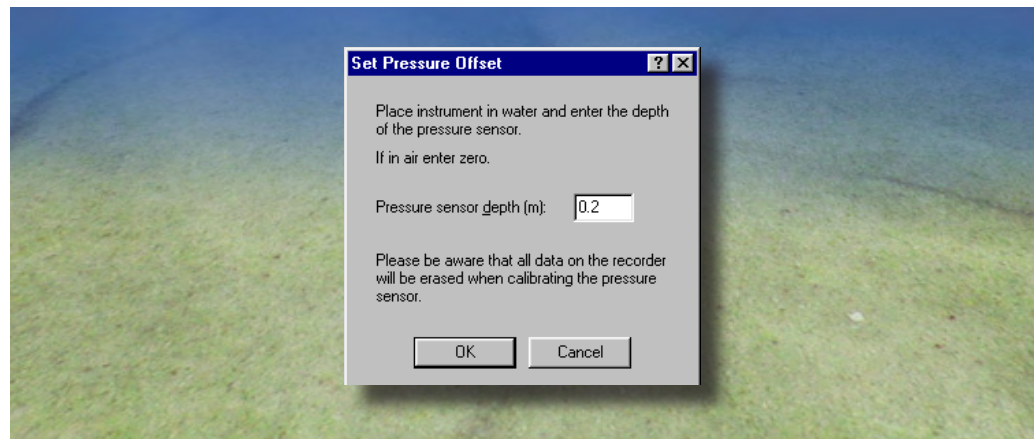

## Calibrating the Compass

The compass calibration is designed to adjust for magnetic materials that may be present in your deployment frame or mooring structure. As a consequence, calibration of the compass should take place after the Aquadopp Profiler has been mounted in its frame or mooring. Be sure to mount all other equipment and materials that is to be attached to the frame or mooring and conduct the procedure outdoors, away from other possible magnetic elements.

**To calibrate the compass, do as follows:**

- 1 Assemble the frame or mooring structure completely, with Aquadopp Profiler mounted, be sure to include any external battery canisters (if applicable), and the extra ballast needed to create a stable structure. Connect the Aquadopp profiler to the computer as usual.
- 2 Make sure it is possible to rotate the entire system (instrument + frame/ mooring, including any extra equipment) 360° around the instrument's z-axis. For a definition of the z-axis, turn to *Chapter 4—Functional Description*.
- 3 Click **On-line** > **Compass Calibration**. This will produce the following dialogue box:

The Compass Calibration dialogue box.

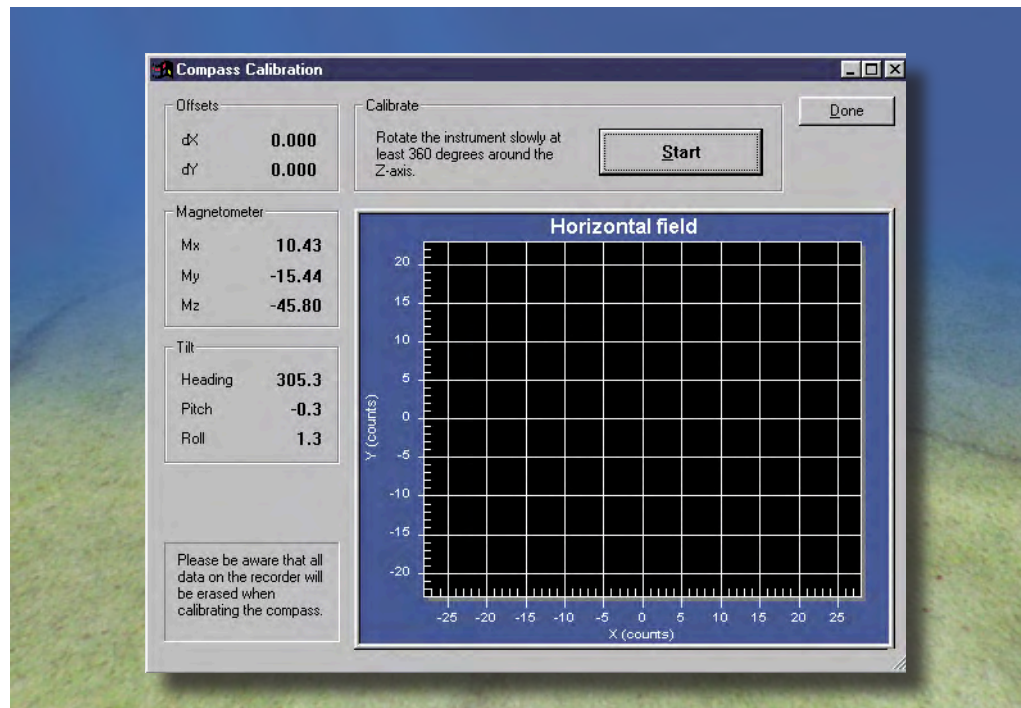

Rotate the entire system slowly around the z-axis of the Aquadopp Profiler. Turn to Chapter 4 for a definition of the z-axis.

- 4 Click **Start** and rotate the entire system slowly 360° around the z-axis of the Aquadopp Profiler. An example of successful rotation is shown below.
- 5 To make use of the obtained values, click **Done**. You will be prompted to confirm that the new values shall be transferred to the Aquadopp to serve as the new compass setting.

The Compass Calibration dialogue box after a successful calibration has been made.

When doing this in-situ with the Aquadopp mounted in a heavy mooring structure, you cannot expect to end up with a circle as perfect as this one. However, we recommend you to do this slowly in an attempt to come as close to the ideal circle as possible.

The estimated maximum error after calibration is the estimated error resulting from non-horizontal rotation (oblique circle).

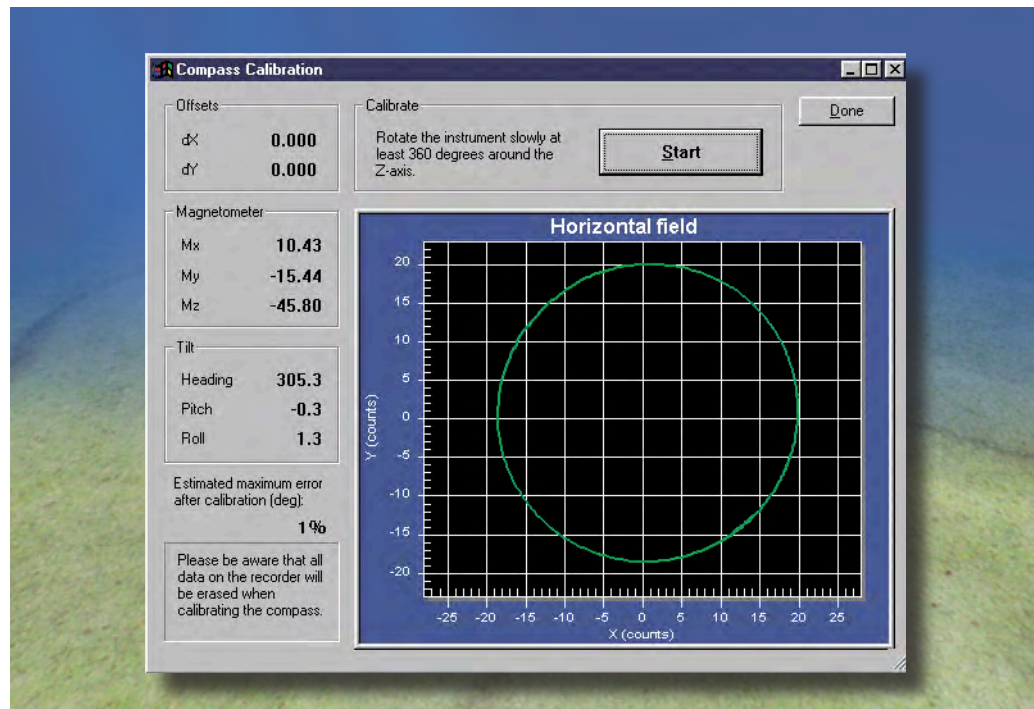

## Upgrading the Firmware

By the term *firmware* we are referring to the internal software of the Aquadopp Profiler, as opposed to the AquaPro software running on a PC and described in this manual.

When you purchase a brand new Aquadopp Profiler from the factory, it has a firmware version matching the PC software. Hence no firmware upgrade will be needed before you start using your Aquadopp Profiler.

However, new functionality (and in rare cases bugfixes) is likely to be offered in the future, requiring that the firmware is upgraded. New firmware is posted on our web site at <http://www.nortek-as.com/support.php>. You will need to register to get access, but access is otherwise free of charge.

### To do a firmware upgrade:

- 1 Go to <http://www.nortek-as.com/support.php>, register if this is the first time, otherwise just log into the **User Room**, click on **Software & Firmware** and download the new firmware file to your computer (save it).
- 2 Make sure your Aquadopp Profiler is connected to the computer and that they communicates well together.
- 3 Click on **Configuration > Firmware Upgrade** in the AquaPro software, browse to the downloaded firmware file and select it.

This will produce the following dialogue box:

Firmware upgrade in progress

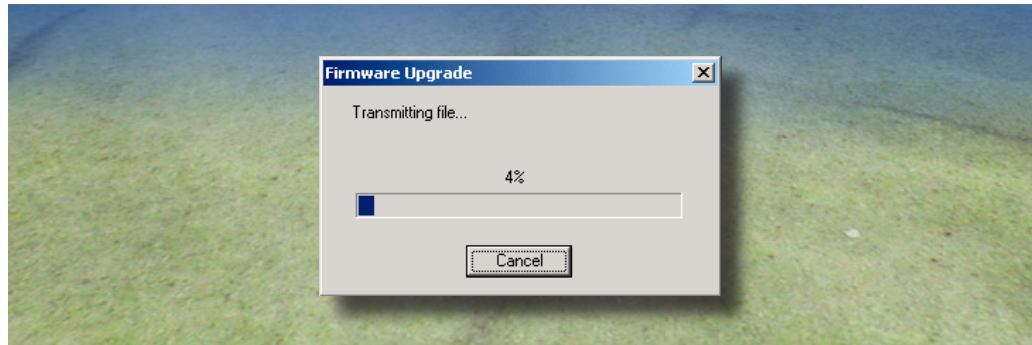

To ensure that the Aquadopp Profiler firmware avoids becoming corrupted because the download transmission failed during the download process, the Aquadopp runs a check on the received file before it is allowed to replace the existing firmware.

Once verified as valid, the following dialogue box will appear ...

The instrument warns you that any data acquired in the Aquadopp Profiler will be erased to avoid inconsistencies

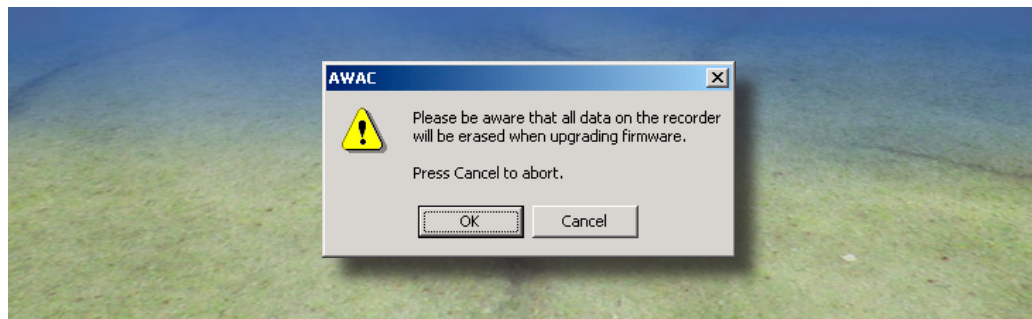

... just to warn you that any data residing in the Aquadopp Profiler will be erased to avoid inconsistencies. In other words, transfer data that you would like to retain to your PC *before* you upgrade the firmware.

## Mounting Guidelines

The Aquadopp Profiler is often used in areas with large waves. Large waves generate strong orbital currents, which again means that the mounting frame will be subject to strong forces. To survive the wave forces the mounting frame should be compact at the same time as it should be heavy. Contact Nortek if you need ideas on what the mounting frame should look like.

**The Aquadopp Profiler has been designed for easy mounting and deployment. The following guidelines should give you the best possible data:**

- When mounting the Aquadopp Profiler near large obstructions (bridges, piers, walls, etc.), ensure that the acoustic beams do not “see” any obstructions. Objects interfering with the beams may damage or destroy your data.

- Keep the Aquadopp Profiler away from magnetic materials.
- Consider the frame or cable holding the Aquadopp Profiler, and the structure it is mounted on. Nearby magnetic materials could cause the directional readings to be in error.
- Consider the effects large objects will have on the flow itself. A rough rule of thumb is that objects disturb the flow as far as 10 diameters away from the object. Flow disturbance is greatest directly downstream in the wake behind the object. Flow disturbance affects your measurements by changing the flow and by making it non-uniform across the Aquadopp Profiler's beams.
- All acoustic transducers must be submerged during data collection. Operating with the transducers out of water will not cause damage, but your data will be meaningless.
- The pressure sensor can handle pressure that is about 150% of its maximum reading. For example, the standard 100m pressure sensor can safely withstand 150m depth.

## Using Long Cables

RS232 data communication at 9600 baud will normally work fine for cables up to 50 m long, depending on the environment.

If you want to run a longer cable, you can switch to RS 422 by installing a different wiring harness you can get from Nortek.

You can also try using RS 232 with longer cables by reducing the baud rate. Keep in mind that RS 422 is a more reliable means of communication than RS 232—changing environmental conditions could cause RS 232 communications to fail over a long wire without apparent reason.

You should consider the voltage drop across the cable, particularly if you use the two highest power settings (see *Deployment planning* in *Chapter 6—Operation* for details on this). Design your power supply and cable so that the voltage stays below 16 VDC, and never falls below 9 VDC.

## Changing the Baud Rate

You may specify two separate baud rates for the Aquadopp Profiler. The primary baud rate setting applies to normal communication and data transfer. You can also set a secondary baud rate for data download and firmware upgrades (the **Recorder/Configuration baud rate**). A higher baud rate speeds up large file transfers and is appropriate when you have a short serial cable and a relatively noise-free environment.



**Note!** If data download is interrupted the Aquadopp Profiler may be left with a baud rate setting other than the one used for normal communication. When the software tries to establish communication in such cases, it may spend a few moments searching for the current baud rate.

The standard baud rate is 9600, and we recommend that you use this baud rate unless you have a good reason to change it.

**To change the baud rate and make it permanent, do the following:**

- 1** Set up the Aquadopp Profiler and connect it to your computer.
- 2** Set the baud rate in **Communication > Serial Port** to the baud rate you prefer. Start a deployment, and then stop it. The last step makes the new baud rate permanent. If you remove power and reapply it, the Aquadopp Profiler will re-awake with the new baud rate.



# CHAPTER 6

## Operation

---

The AquaPro program has been designed to aid your planning, execution, recovery and processing of autonomous Aquadopp Profiler deployments. However, the AquaPro program can also be used to control the instrument in real time applications. Real time applications are covered in *Chapter 7—Real Time Applications*. How to install the AquaPro software is described in *Chapter 5—Preparing the Instrumentation*.

This chapter provides a detailed description of the use of the AquaPro program for autonomous deployment setups.

**Tip!** You can easily use a radio to check that the Aquadopp Profiler is running. The Aquadopp Profiler transmits energy at 0.4, 0.6, 1, or 2 MHz, and an AM radio will pick up these signals or their harmonics. Be sure to listen first with the Aquadopp Profiler on the bench to choose the best frequency and to learn to identify the Aquadopp's distinctive sounds.

If you would like to listen to examples, go to our Forum and search for “verifying pinging”. See page 4 for details on the use of our Forum.

## Data Collection

The Aquadopp Profiler system allows for both self-recording and real-time data collection.

### A typical sequence includes:

- 1 Install and/or plug in battery pack. Refer to procedure in *Chapter 6*.
- 2 Install new desiccant, if necessary. Refer to procedure in *Chapter 6*.
- 3 Test the Aquadopp Profiler according to procedure in *Chapter 4*.
- 4 Set PC time.
- 5 Use AquaPro software to plan deployment. Click **Deployment > Planning**.
- 6 Erase recorder. Click **Deployment > Erase Recorder**.
- 7 Start deployment. Click **Deployment > Start Recorder Deployment**.
- 8 Enter a 6-character deployment name.

# A Tour of the AquaPro Desktop

## Title bar and menu bar

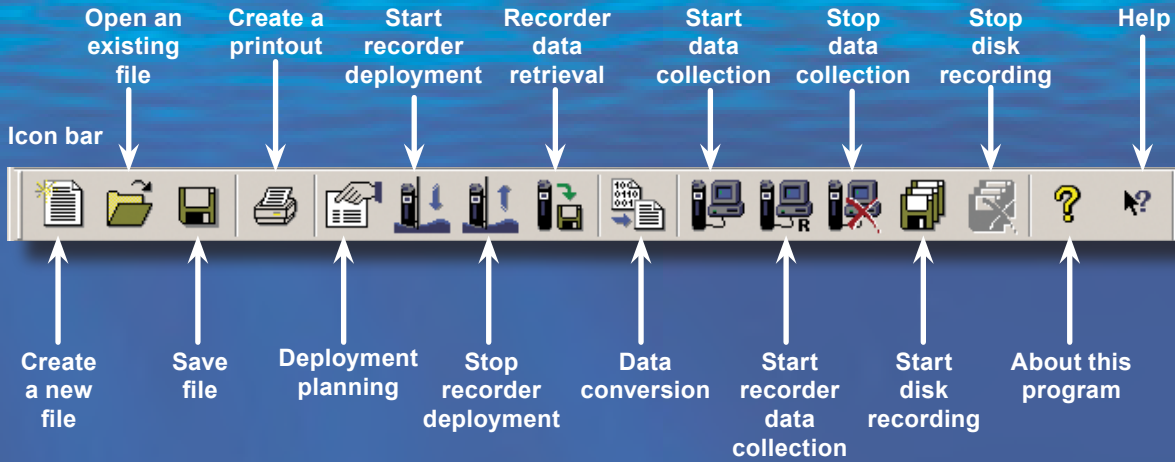
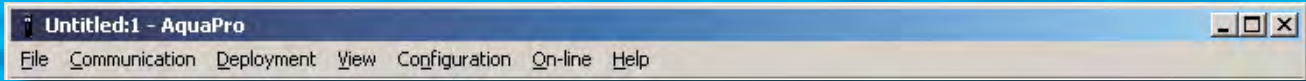

## Display control bar

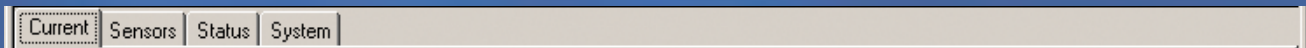

Numerical display. Contents is determined by the Display control bar setting.

Graphical display. Contents is determined by the Data display selection bar setting.

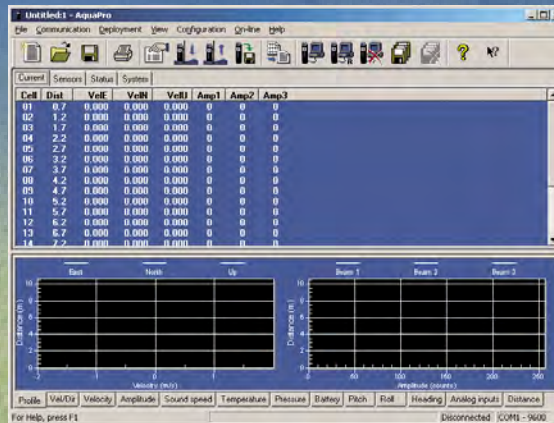

## Data display selection bar

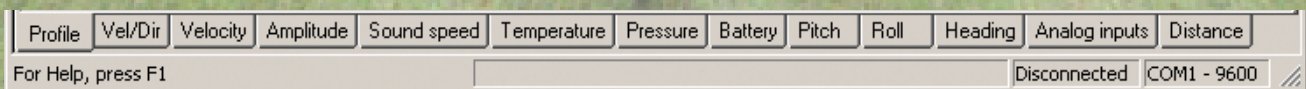

## The AquaPro Pull-down Menus

The **File** menu lets you create new deployments, open existing ones as well as saving files. This menu also lets you print out your graphs and tables as well giving you shortcut access to recently used files.

The **Communication** menu is used to set up the serial communication and to start the Terminal Emulator.

The **Deployment** menu lets you define a deployment regime, start and stop recorder deployment, view a log on what's been taking place, retrieve recorded data, convert the acquired data to ASCII format, and erase the recorder contents.

The **View** menu lets you beef up the display to your liking.

The **Configuration** menu is used to upgrade the firmware to a more recent version and to upgrade the head configuration file, whenever applicable.

The **On-line** menu is used to start and stop data collection with or without the internal recorder, as well as to define a file name for the recording to a remote computer's hard disk and to start that recording. In addition this menu lets you set the clock, the pressure offset and calibrate compass and temperature.

The **Help** menu provides access to Help topics as well as an on-line version of this manual and program version information.

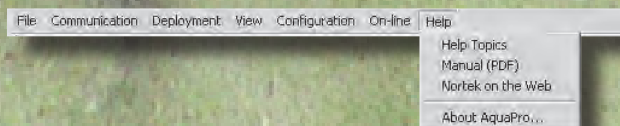
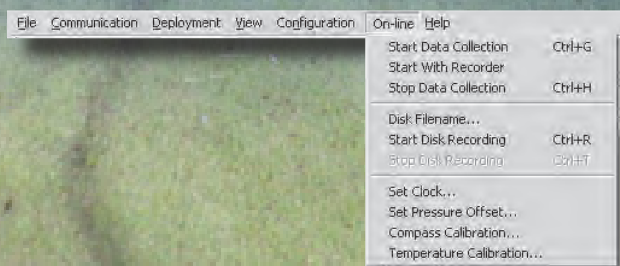
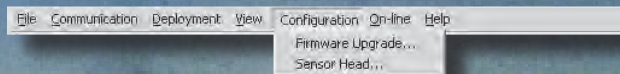
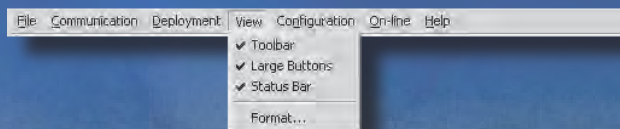
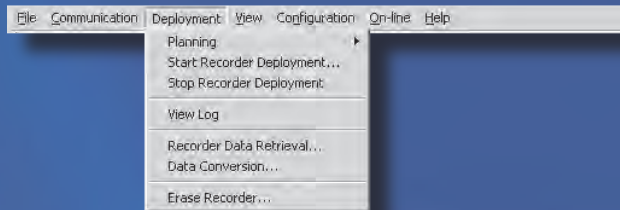
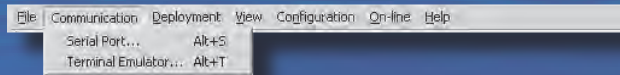
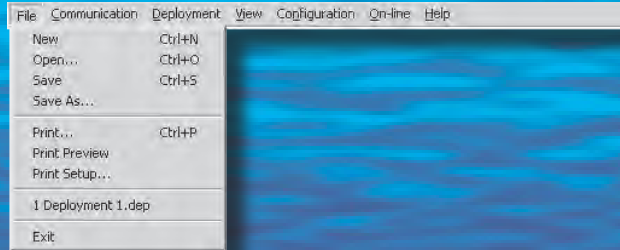

- 9 Set Aquadopp time to PC time.
- 10 If appropriate, set a delayed start-up time.
- 11 Disconnect cable and install dummy plug.
- 12 Verify pinging with AM radio just prior to deployment.
- 13 Install on site. Ensure the acoustic beams point where you want and that they are not obstructed.

## Deployment Planning

On the main menu, select **Planning** from the **Deployment** pull-down menu or press the **Deployment Planning** toolbar button to activate the planning dialogue box. The **Planning** submenu displays three options that may serve as a starting point for your deployment planning.

Producing the **Deployment Planning** menu.

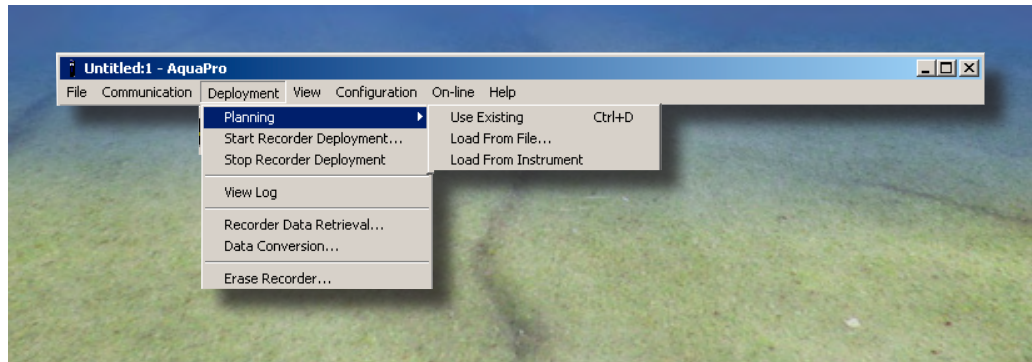

- Select **Use Existing** to start with the previous settings (This selection corresponds to the **Deployment Planning** toolbar button).
- Select **Load From File** to read settings from a deployment (.dep) file.
- Select **Load From Instrument** to read settings from the instrument.

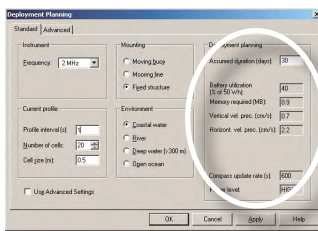

The **Deployment planning pane** shows the consequences of your setup choices in terms of battery utilization, memory requirements, and velocity precision.

The **Deployment planning** menu contains all parameters required to specify the operation of the instrument. For convenience, the dialogue is tabbed, consisting of a **Standard** tab and an **Advanced** tab.

The **Standard** tab lets you input main settings like profile interval, number of cells and cell size along with typical mounting and the environment (coastal water, river, deep water, and open ocean). Based on your settings the program will choose a set of default settings for the deployment.

If you want more control of the deployment setup, click the **Use advanced settings**, go to the **Advanced** tab and refine your setup. Remember to click on **Update from Standard** to refresh the settings already made to avoid visual inconsistency.

The **Deployment planning pane** (the right part of the dialogue box—see Fig.) displays performance parameters that are automatically updated as you change the parameter settings. When finished, press **OK** to accept the changes.

## The Deployment Planning Menu Standard tab

The **Standard tab** provides convenient default settings for typical environments and mounting arrangements.

**Frequency.** Choose 600 kHz, 1 MHz or 2 MHz depending on the frequency of your instrument.

**Mounting.** Choose the setting that best fits your deployment. **Moving buoy** and **Mooring line** mounting requires more frequent compass reading and hence more battery power spent. To see the consequence, watch the effect on battery utilization.

**Deployment planning.** Enter the number of days you intend to collect data. This value will, together with the other deployment parameters and the hardware configuration, be used to calculate the performance parameters and hence the total battery utilization, recorder memory requirements and velocity precision (expressed as the standard deviation of the noise).

This is the **Standard tab**

**Profile interval** is the time between each measurement, i.e. the data output rate.

**Number of cells** is the number of current measuring cells along each beam.

**Cell size** is the length of each cell along the beams.

Default compass update rate and power level to be used, unless you choose to activate the advanced settings.

**Environment.** Choose the setting that best fits your deployment. The setting determines the instrument transmit level. To see the consequence, watch the effect on battery utilization.

Because coastal waters and rivers normally have high backscatter, these choices reduce transmit power (and hence battery utilization). If you are working in such areas, but still know you have low backscatter, select **Deep water** or **Open ocean** instead.

If the default settings fail to provide the deployment setup control you need, you should use the Advanced settings. Check this box for **Advanced setting** to become effective.

Click **OK** to leave menu putting changes into effect.

Click **Cancel** to leave menu undoing any changes.

Click **Apply** to put changes into effect without leaving the menu.

Click **Help** to start the context sensitive Help system.

## The Deployment Planning Menu Advanced tab

The **Advanced tab** gives you detailed control of the setup when the default settings won't suffice.

**Average interval** is the time the instrument is actively measuring through the profile interval. The instrument will be in sleep mode during the rest of the profile interval.

This is the **Advanced tab**

**Blanking distance** is the distance from the sensor to the start of the first measurement cell.

**Compass update rate.** Compass reading consumes energy. It can be done every second, but you may also set it to a longer interval.

**Sound propagation speed** Key in the salinity (to have the speed calculated based on salinity and temperature) or use a fixed sound speed. Salinity is typically 35 in the ocean and 0 in fresh water.

**Measurement load.** The percentage of time spent in Active (data collecting) mode per second. Uncheck **Auto** to gain manual control of this.

**Power level.** Sets the amount of acoustic energy emitted into the water. Level difference between High and low is 20dB, step size is about 6dB. Use high setting unless you are sure of high backscatter or only using short range.

**File wrapping.** When checked the internal recorder operates in ring-buffer mode to ensure that it always holds the latest data. If unchecked data logging stops when the recorder is full.

This part is similar the same of the **Standard tab** and explained there.

**Coordinate system.** Select ENU, XYZ or Beam (See *Chapter 4* for more on this)

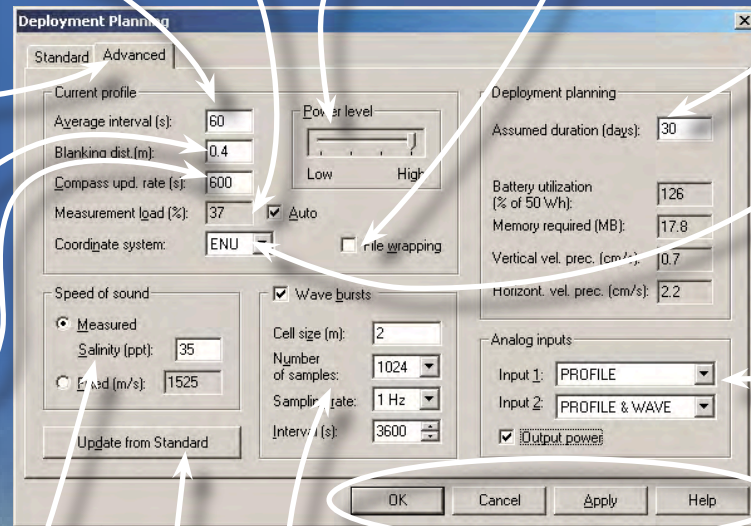

Refresh settings to reflect settings made in the **Standard tab**.

**Wave bursts.** Must be checked to collect velocity and pressure data for wave spectra computations. See text for more on this.

Click **OK** to leave menu putting changes into effect.

Click **Cancel** to leave menu undoing any changes.

Click **Apply** to put changes into effect without leaving the menu.

Click **Help** to start the context sensitive Help system.

**Analogue inputs.** The instrument can read two analogue inputs at the same time. The inputs are typically used to connect a CT sensor to the system. You may specify when the sampling of the external sensor shall take place – during wave measurements, during profile measurements or during both.



Use the **Open/Save** commands in the **File** menu (or the corresponding toolbar buttons) to save the deployment parameters as a file at any given time. You may then reload it when it is time to actually deploy the instrument.

## Wave Bursts

When collecting velocity and pressure data for wave spectra computations, observe that the instrument will not do profiling and wave burst measurements at the same time and that wave measurements are given priority (see Fig. below).

**Cell size** can be 2–8 m for 600 kHz systems, 1–4 m for 1 MHz systems, and 0.5–2 m for 2 MHz systems. The lower setting is recommended for shallow water deployments only. Maximum recommended depth for wave burst measurement is 20 m.

**Number of samples** can be 512, 1024 or 2048. The higher the number the better the estimate will be at the expense of increased time between profiler measurements.

The Aquadopp Profiler measures profile and waves sequentially. In case of conflict, wave measurements have priority over profile measurements.

The ASCII conversion software can interpolate the missing profile.

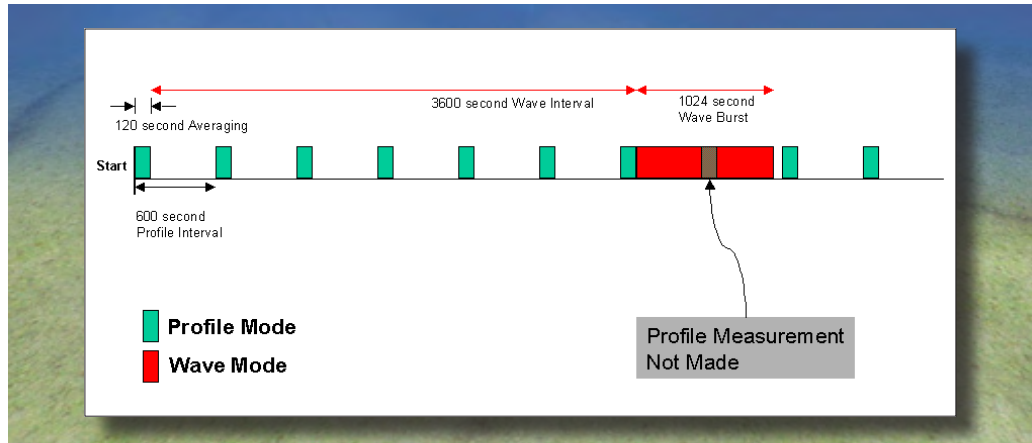

**Sampling rate** determines the length of the wave burst. **Example:** 2 Hz and 1024 samples will cause the wave burst to take 512 seconds to do.

**Interval** is the time between each wave burst.

**What are counts really?**

For signal strength, Nortek frequently make use of the word *counts*, which obviously seem to be connected to the decibel term, but how and why?

Inside the Aquadopp profiler there are circuitries for the amplification of input signals. The number of counts is an indicator of how much gain we must apply to a signal – the less gain needed, the higher the input signal level is. The number of counts is inversely proportional to the logarithm of the gain setting, which means that a higher number of counts reflects a need for less amplification than a lower number of counts will do.

Strong signals have a higher noise immunity and they correlate much better than weak signals do.

For the Aquadopp signal processing, 1 count  $\approx$  0.4–0.45dB.

Observe that the term counts is also used in other contexts (viz. the analogue inputs) with a different relationship, not related to dB. Here 0V equals 0 counts, 5V equals 65535 counts, and 2.5V equals 32768 counts (in other words a 16 bit system)

## Use with other Instruments

The Aquadopp Profiler comes with two analogue inputs to enable e.g. a CT sensor to be connected to your system. The instrument can read both analogue inputs at the same time.

### The following should be observed:

- The **Deployment planning** menu is used to determine when to sample the external sensors. Choose between when measuring wave, when measuring profile or during both.
- The input impedance of the analogue inputs is 470k $\Omega$ /100nF.
- If you want to power the external sensor from the Aquadopp Profiler you must check the **Output power** box. The output power is configured in hardware by Nortek and can be *raw* (i.e. battery power), +5V, or +12V. The raw setting is the default setting and all instruments come with this setting unless otherwise was specified upon ordering.

### To activate powering of the external sensor from the Aquadopp Profiler:

- 1 In the AquaPro software click **Deployment > Planning > Use existing** or use **Load from Instrument**.
- 2 Click **Use Advanced** and go to the **Advanced** tab.
- 3 Define which analogue input (1, 2 or both) to use. **PROFILE** is used to sample data at the same rate as profile measurements are started, while **WAVE** samples every time a wave burst measurement is started. The **PROFILE & WAVE** is used to sample data every time a profile or a wave burst measurement is started. Only one of the inputs can be set to sample while wave measurements are made. A warning will appear if you attempt to set them both to wave related sampling.
- 4 Check the **Output power** box.

- The data from the external sensor will not be affected by the Aquadopp Profiler data quality. For example, the external sensor's data will be totally unaffected even if the Aquadopp Profiler is out of water and thus measuring noise only.
- No powering of the external sensor will take place when the Aquadopp Profiler is in sleep mode. This helps reducing the system's power consumption significantly.

Consequently, any external sensor used must be capable of automatically resuming its duties once the power comes back, and they must do this within 1 sec after power up in order to provide correct data for the first sample.

- Our efforts to reduce the system's power consumption includes a non-constant sampling of the external sensor.

- You should note that when using an external sensor you will need to make your own calculations for power requirements and battery life. The Aquapro software is not able to do this when calculating battery utilization.

The input section of the Aquadopp's analogue input looks like this:

The Aquadopp's analogue input circuitry – see text for details on functionality.

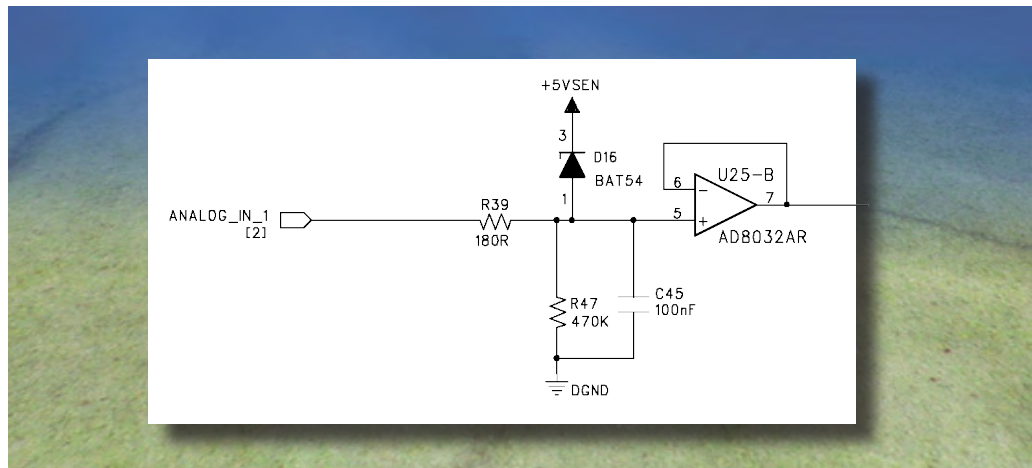

To protect the Aquadopp circuitry against external sensors providing an output voltage in excess of +5.0V, there is a clamping diode on the input with a current limiting resistor in series. The diode will conduct at voltages above approximately 5.3V.

To achieve stable conditions during testing, the +5V\_SEN net can be powered up from command mode by sending the hex command **435001C4** from the terminal emulator.

## Starting Recorder Deployment

Before you start a deployment, either define a new deployment configuration (deployment planning) or load a saved configuration from memory. Then click **Deployment > Start Recorder Deployment**, and enter a short deployment name of no more than 6 characters, which will be used for the internal data file. The program allows you to set the Aquadopp Profiler's internal clock (see below), and then gives you a final review on the instrument setup, just before you start it up.

We urge you to verify that the battery level and available memory match your deployment setup.

The software creates a log file using your deployment name with the setup parameters. You should keep this file in your records.

Use a delayed startup either to make sure the Aquadopp Profiler starts data collection on the hour, or to conserve batteries for a deployment that starts some time in the future. You can start an Aquadopp Profiler deployment well in advance of when you plan to install it on site, and use a delayed startup to conserve the Aquadopp Profiler's battery and recording resources for the actual deployment.

Starting a recorder deployment.

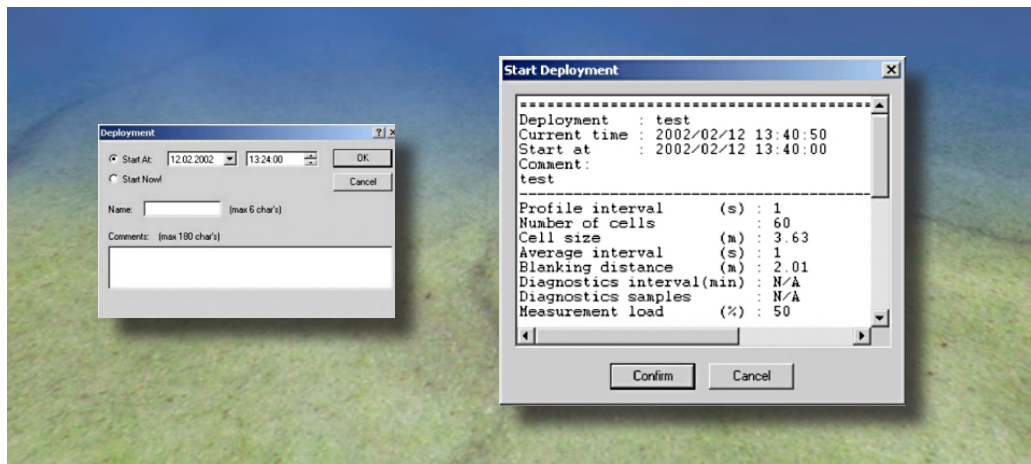

## Setting the Instrument's Real Time Clock

The software allows you to set the Aquadopp Profiler time of day and a delayed startup time when you start the deployment (see above). The easiest way to set the Aquadopp Profiler time is to use the PC time setting. We recommend you to make sure the PC time is set correctly before you start the deployment. An important reason to set the correct time may be to synchronize a group of Aquadopps with one another or with other sensors. The real time clock of the Aquadopp Profiler has an accuracy of approximately  $\pm 20$  seconds per year which is far better than a typical PC clock. If you want to take advantage of the Aquadopp Profiler clock to keep data from several instruments synchronized, you may want to set the PC time with a GPS card.

Setting the real time clock in the Aquadopp Profiler.

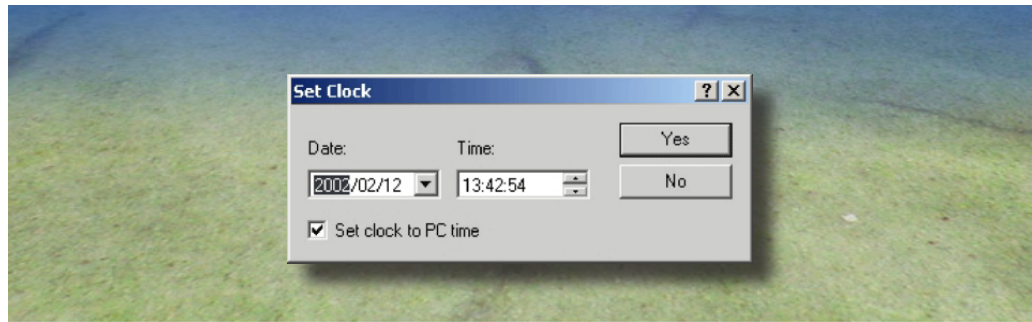

## Stopping Recorder Deployment

Before you tell the Aquadopp Profiler to stop collecting data, verify that the computer time is accurate. The software will compare the computer time with the Aquadopp Profiler time, and you can use this information to quantify clock drifts. After you recover your Aquadopp, use the Aquadopp Profiler software to stop recording. After you connect the Aquadopp Profiler to your computer, click **Deployment > Stop Recorder Deployment** or click the corresponding icon.

When the program tells the Aquadopp to stop collecting data, it displays both the Aquadopp Profiler time and the computer time. We recommend that you keep a record of the differences, which can be used to correct the exact time of the Aquadopp samples—assuming that your PC clock is correct.

When you stop the deployment computer time and instrument time will both appear for comparison.

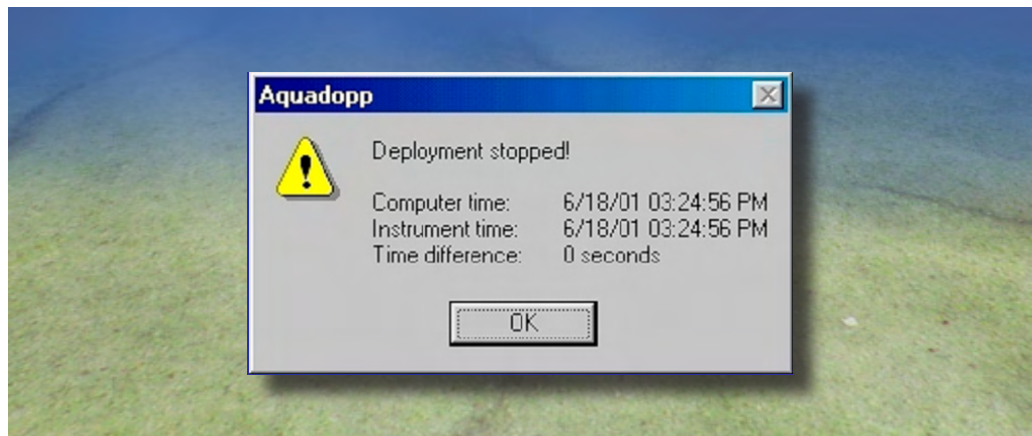



# CHAPTER 7

## Real Time Applications

---

Autonomous deployments are by far the most common Aquadopp Profiler application. However, you may just as well use it in real time applications. Such applications may, of course, be part of permanent or semi-permanent environmental monitoring systems, but from time to time you may want to set up a real time system to test your application before you actually deploy the instrument. This chapter outlines the real time features of the AquaPro program.

We recommend users with real time application requirements to check [www.nortek.no](http://www.nortek.no) regularly for new advances in our range of online software programs.

### Online Solutions

For cables not longer than 50 m, RS 232 communication at 9 600 baud will normally work fine. If you want to run a longer cable, you can switch to RS 422 by installing a different wiring harness, which can be obtained from Nortek.

You can also try using RS 232 with longer cables by reducing the baud rate. Keep in mind that RS 422 is a more reliable means of communication than RS 232—changing environmental conditions could cause RS 232 communications to fail over a long wire without apparent reason.

You should consider the voltage drop across the cable, particularly if you use the two highest power settings (see *Deployment planning* in *Chapter 6—Operation* for details on this). Design your power supply and cable so that the voltage stays below 16 VDC, and never falls below 9 VDC.

Permanent online installations may include other communication solutions,

such as underwater modems, surface buoys, GSM modems and/or Iridium communication. One example of such an installation is shown overleaf.

Permanent real time installations of Aquadopp Profilers have a lot in common with real time installations using the Nortek AWAC. Examples of online solutions can be found in our AWAC brochure, which can be downloaded from <http://www.nortek-as.com/brochures/AWAC.pdf>. Articles on the subject are also available at <http://www.nortekusa.com>.

See also *Mounting Guidelines* in *Chapter 5* for tips on deployments.

An online (real time) application example. More on online solutions can be found on our web sites. See text for details.

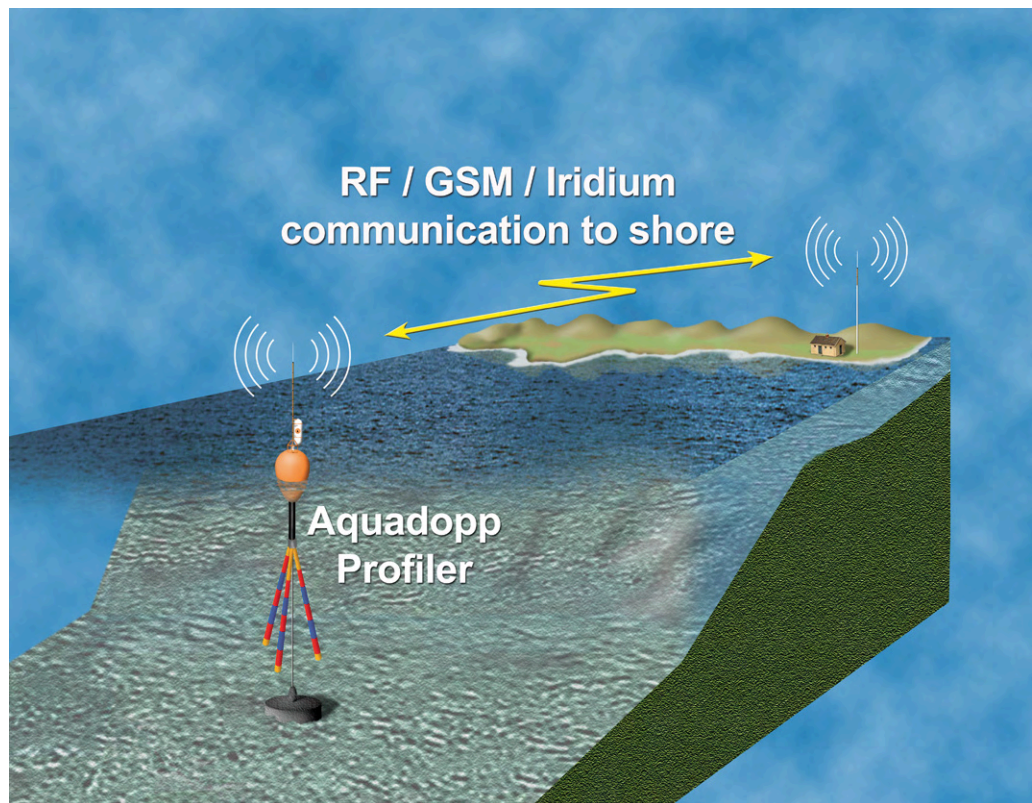

## Recording Data Internally as a Backup

You can set the instrument to record data internally while at the same time sending data out the serial port. To do this, use **Online > Start with recorder** or click the corresponding icon.

If you have an internal backup battery, then you can record backup data in the event of power failures.

The Aquadopp has two modes of internal recording. The standard mode is to stop recording when the recorder is full. The Aquadopp can also use a wrap-around mode in which it keeps only the most recent data, overwriting the oldest data when the recorder is full. Wrap-around data recording makes good sense when



you are backing up external recording against the possibility of power failures. This is set up in the **Deployment planning** menu (see *Chapter 6* for details).

## Online Viewing of Acquired Data

Online presentation of acquired data can be numerical (tabulated) as well as graphical.

The two menu bars used for determining what to display

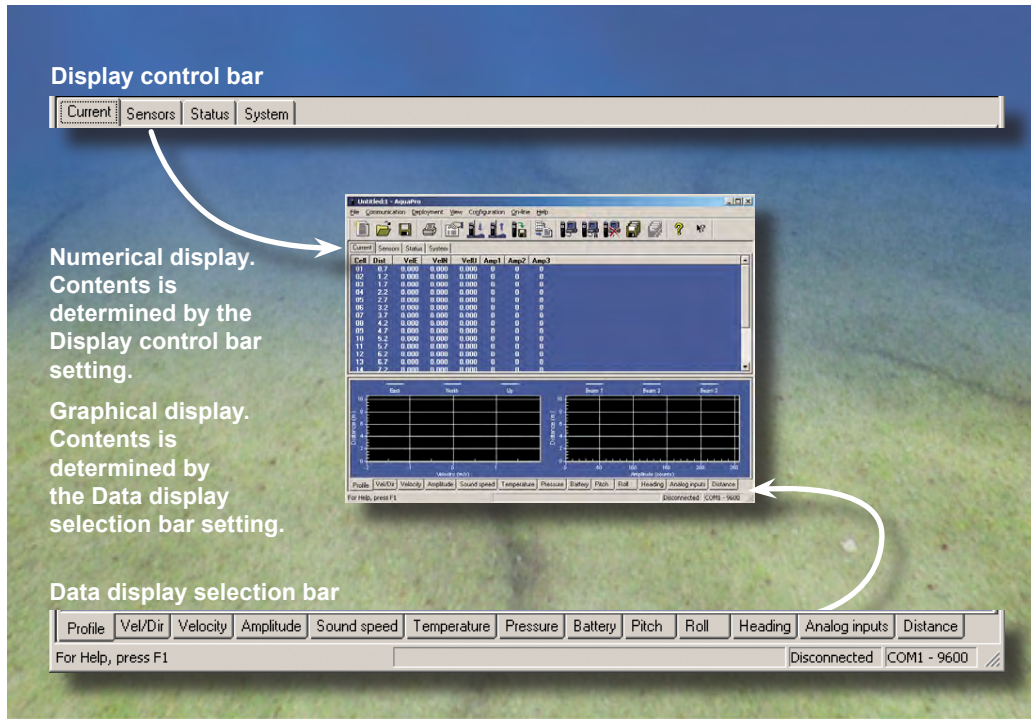

## Numerical View Options

The numerical view options include tabulated presentations of the measured current profiles, sensor information, system status, and system information.

**The current tab** provides a tabulation of the measured current profiles per cell, including the measured amplitudes indicating the received signal strength.

The **current tab** provides a tabulation of the measured current profiles per cell and the measured amplitudes.

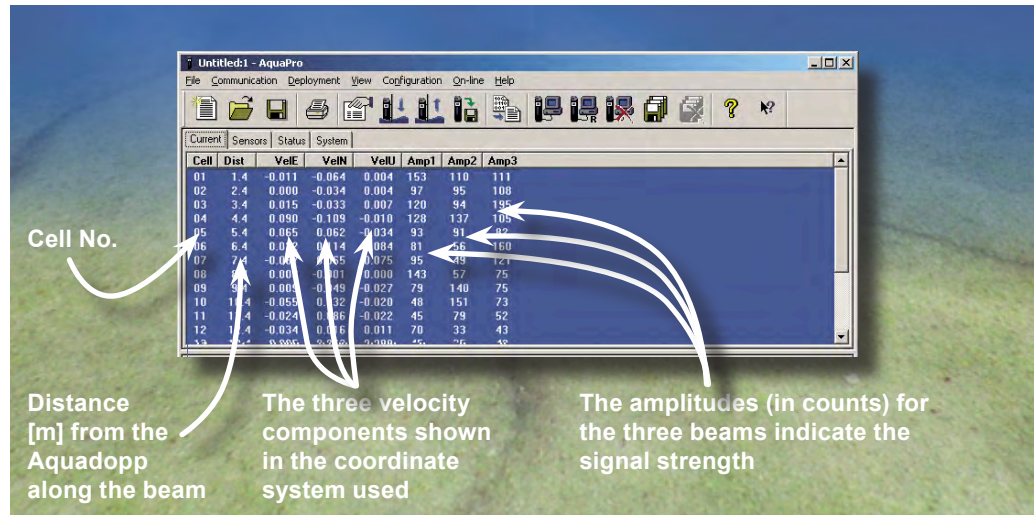

The **sensors tab** provides information about the sensor and the reading of the analogue inputs.

The **Sensors tab** provides information about the sensor and the reading of the analogue inputs.

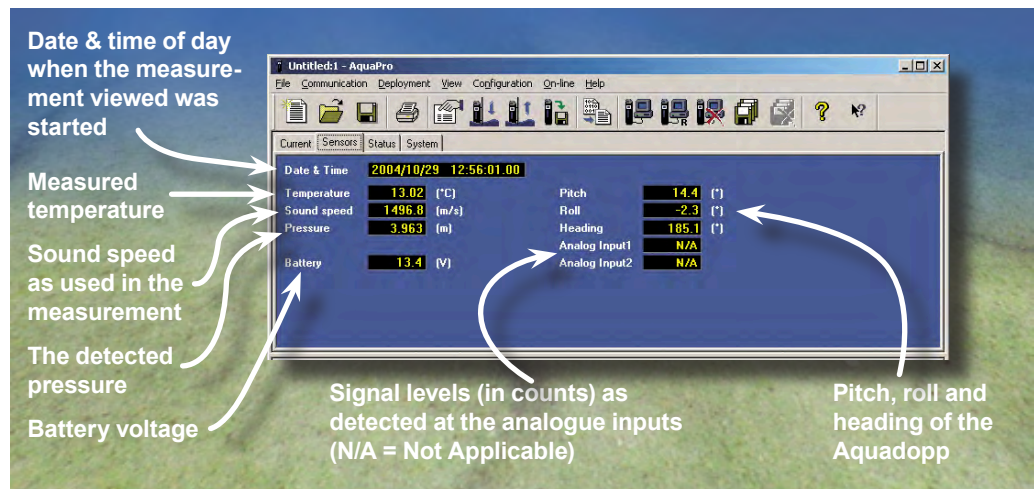

The **status tab** provides information on the path to the disk file and its size. Any errors occurring will be indicated here.

The **Status** tab provides information on the disk file location and its size.

**Date & time of day when the measurement viewed was started**

**Disk file shows the name of the disk file in use for data recording. OFF is displayed when no data are stored to the computer disk during an online measurement**

**Error and status codes – see text for details**

**Current size of the file being recorded onto the computer's hard disk**

**Error codes**

Bit 7	Bit 6	Bit 5	Bit 4	Bit 3	Bit 2	Bit 1	Bit 0
Not used	Not used	Not used	Flash	Tag bit	Sensor data	Measurement data	Compass
			0=OK 1= Error	0=OK 1= Error	0=OK 1= Error	0=OK 1= Error	0=OK 1= Error

**Status codes**

Bit 7 & 6	Bit 5 & 4	Bit 3	Bit 2	Bit 1	Bit 0
Power level	Wakeup state	Roll	Pitch	Scaling	Orientation
00 = 0 (high)	00 = bad power	0 = OK	0 = OK	0 = mm/s	0 = up
01 = 1	01 = power applied	1 = out of range	1 = out of range	1 = 0.1mm/s	1 = down
10 = 2	10 = break				
11 = 3 (low)	11 = RTC alarm				

The **system** tab provides information on the system itself.

The **System** tab provides information about the system itself.

**Date & time of day when the measurement viewed was started**

**Disk file shows the name of the disk file in use for data recording. OFF is displayed when no data are stored to the computer disk during an online measurement**

**Error and status codes – see text for details**

**Current size of the file being recorded onto the computer's hard disk**

## Graphical View Setup Options

The graphical tabs determine what to display in the lower part of the AWAC software main screen. By right-clicking the mouse whilst positioned in the graph area, you may customize the display.

### Customizing the Display

To be able to customize the graphical display:

- Whilst positioned in the graph area, right-click the mouse. A context-sensitive menu will now appear.

If you right-click the mouse whilst in the graph area, a context-sensitive menu will appear.

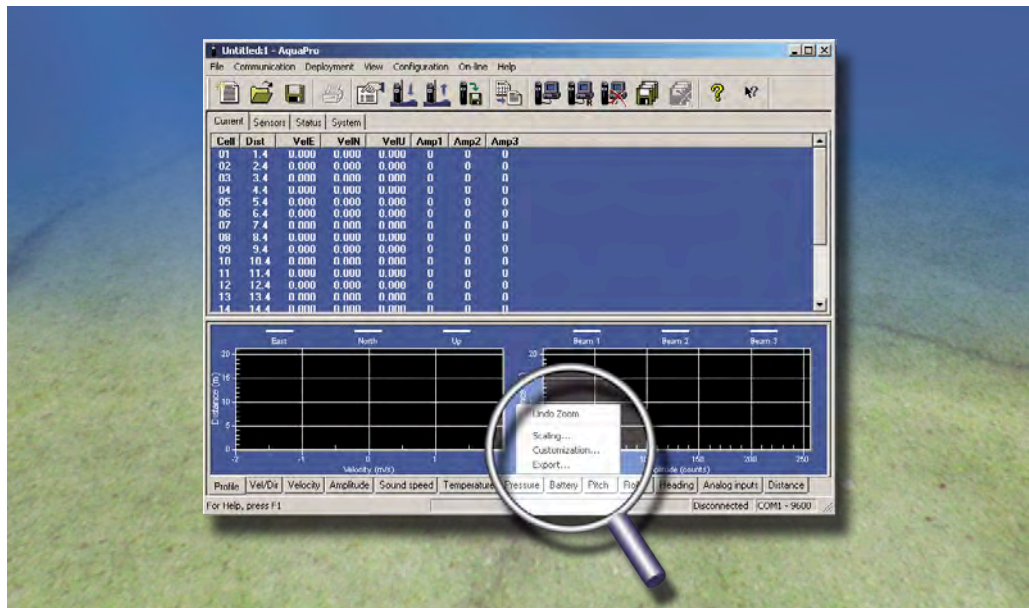

To change the time scale:

- In the context-sensitive menu, click the **Scaling...** or **Scale/Data...** The exact name and appearance of this submenu depends on the function displayed at the moment you right-clicked. If **Scaling** appears ghosted, there is nothing to set for the function currently displayed.

The Scaling submenu comes in two flavours; with and without bin (cell) number specification. This choice appears only when meaningful. In addition, the scaling submenu lets you define the time span in seconds for level vs. time displays, and the data range (vertical axis setting). For profiles, the scaling refers to the levels and not to the distance span shown. You may also select autoscaling in some cases.

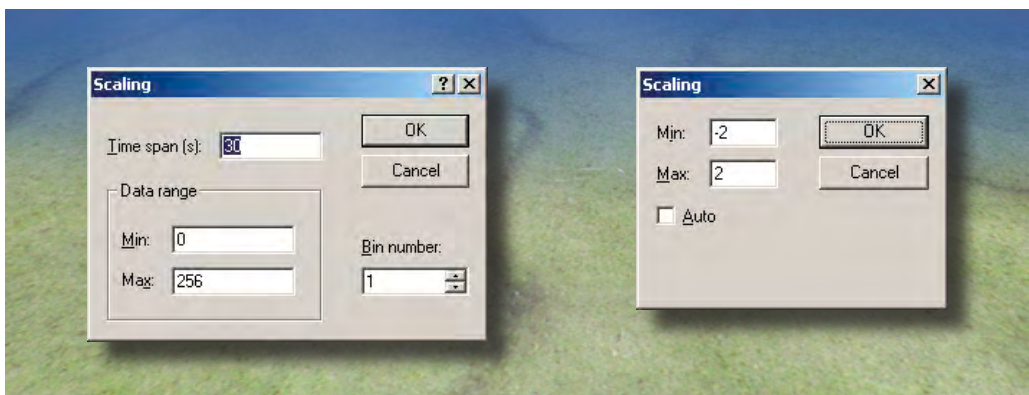

**To change the look of the graphs:**

- 1 In the context-sensitive menu, click the **Customization...** This will produce a tabbed dialogue box.
- 2 Set the parameters as required for your application. Parameters are explained in the following.

**The General Tab**

The **General** tab of the graphical display **Customization** dialogue box.

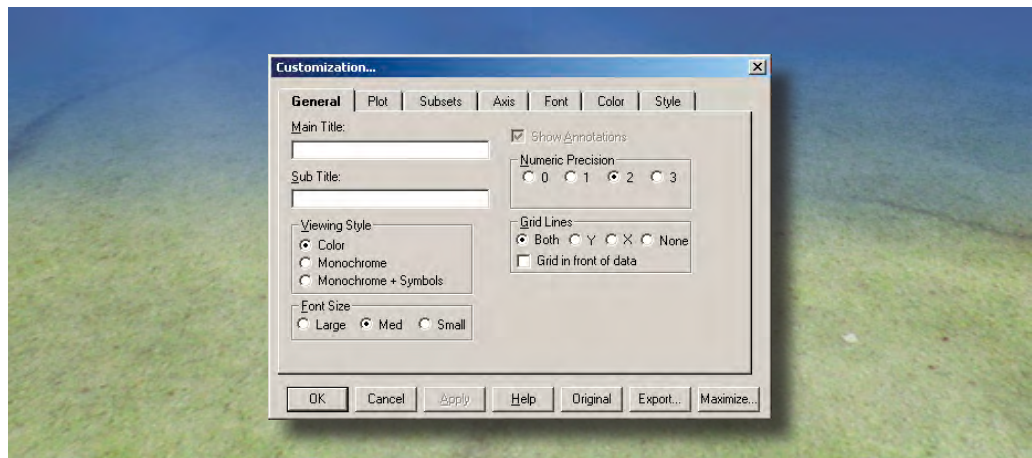

**Main Title & Sub Title.** These two edit-boxes allow adding, editing, and deletion of main and sub titles. If no title is present, entering one will add one. If you remove all the characters from a title, the title will be deleted from the image.

**Viewing Style.** The graph supports three viewing styles:

- Color
- Monochrome
- Monochrome with Symbols

This customization allows you to quickly adjust the image to best suit printing on a monochrome printer. If fewer than four subsets are to be included in a graph, then the Monochrome setting will probably be the best choice. If four or more subsets are to be included in the graph, then Monochrome with Symbols will help distinguish between the different subsets.

**Font Size.** The graph supports three font sizes, Large, Medium, and Small. This gives you the option of selecting the font size that is most readable. When printing the graph, a font size of Medium or Small is suggested.

**Numeric precision.** Defines the number decimals to be used when placing data labels onto the graph, and when exporting Text/Data via the Export Dialogue box.

**Grid Lines.** The graph can contain vertical grid lines, horizontal grid lines, both vertical and horizontal grid lines, or no grid lines. Grid lines can be made to appear in front of the graph.

The **Plot** tab of the graphical display **Customization** dialogue box.

### The Plot Tab

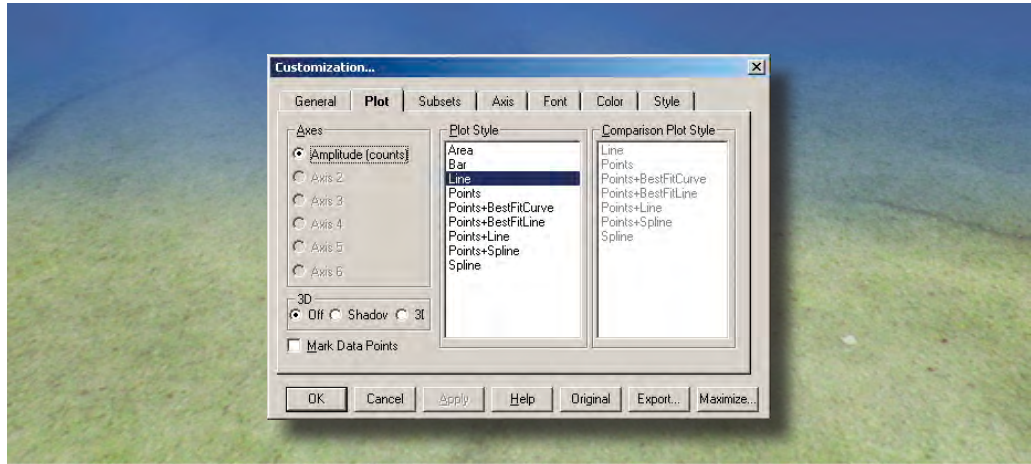

**Axes:** Lists the axes available for customization (context-sensitive – depends on function viewed when this menu was entered).

**Plot Style.** The AquaPro software supports a multitude of plotting methods. Depending on the implementation, some plotting methods may not be available. Also, many but not all of these plotting styles can be set for a secondary comparison plotting style.

If the graph has multiple y-axes, you can control plotting styles for each individual axis by selecting the axis in the axis-button group.

**3D.** This feature allows you to add three-dimensional effects to the plots:

- **Off:** No 3D effect is added.
- **Shadow:** Draw shadows behind bars, points, and the area of an area graph.
- **3D:** Bars and area charts are drawn in a 3D fashion.

**Mark Data Points.** Adds small circular marks at data point locations.

**Comparison Plot Style.** Not used.

### The Subset Tab

The **Subset** tab of the graphical display **Customization** dialogue box.

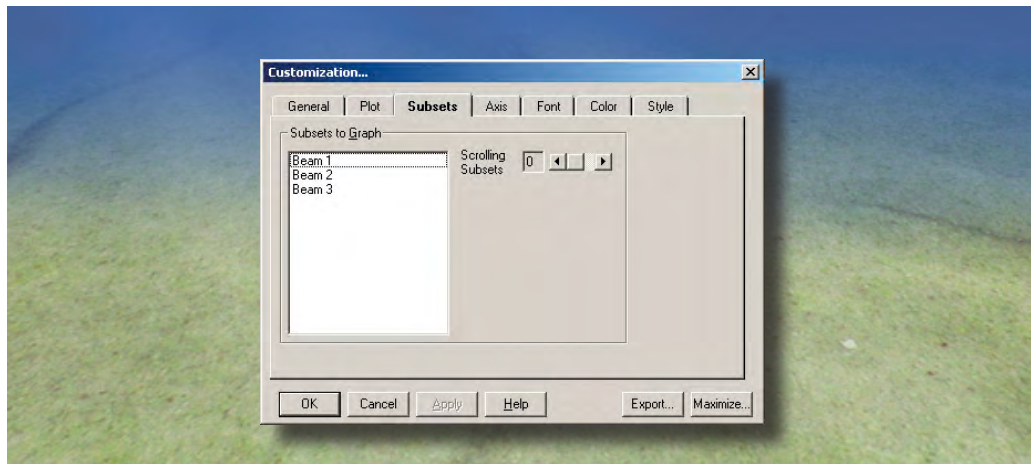

**Subsets.** The subsets tab is used to add annotation to the graphs, typically East, North, Up or Beam 1, Beam 2, Beam 3.

### The Axis Tab

The **Axis** tab of the graphical display **Customization** dialogue box.

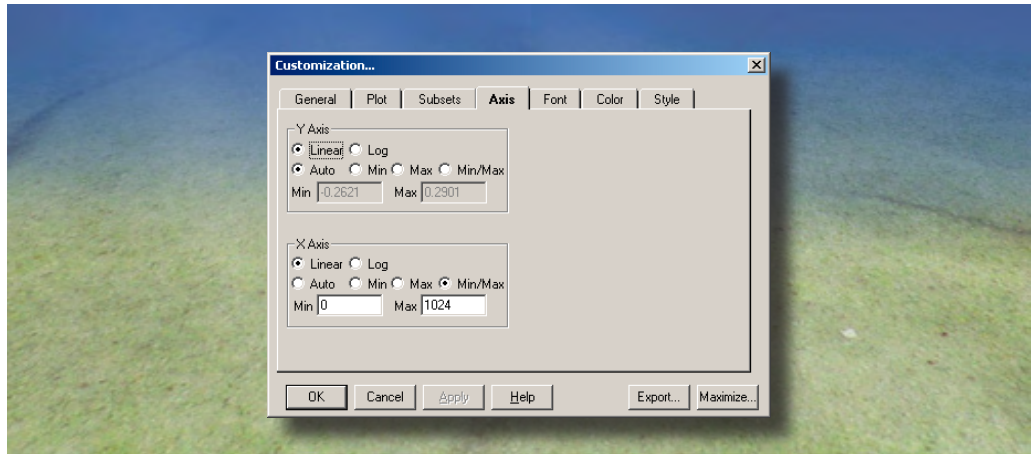

**Axis.** This tab lets you specify axis type and range. Select between linear or logarithmic axes and the following range settings:

- **Auto:** Graph automatically determines min and max based on data.
- **Min:** Manually set Min and automatically set Max.
- **Max:** Manually set Max and automatically set Min.
- **Min/Max:** Manually set both the Min and Max.

Additional parameter fields are available when meaningful, otherwise they appear ghosted.

### The Font Tab

The font tab (not shown) lets you specify font size and appearance for the titles and annotations used in the graphs.

### The Colour Tab

The colour tab (not shown) lets you specify the colours used in the graphs for the curves and the backgrounds.

### The Style Tab

The Style tab (not shown) lets you specify the look of each of the curves appearing in a graph.

## Exporting a Graph

Graphs can be exported to the Windows® clipboard as text, as Windows® Metafile, to a printer, or as files for use in other applications, such as reports and presentations. Normally, we recommend that you save the graph as a file.

**The following formats are available:**

- **Metafile** to be used for *Clipboard*, *File*, and *Printer*
- **Bitmap** to be used for *Clipboard*, and *File*
- **Text/Data** to be used for *Clipboard*, and *File*
- **JPEG** to be used for *File*

**To export a graph:**

- 1 Press **X** when displaying the required graph or click the **Export** key in the Customization Dialogue box.
- 2 Select the type of export desired.
- 3 Select the destination of the export.
- 4 If available, select the size of the image to export.
- 5 Press the Export/Print button.

**Tip!** In general, we recommend that you convert the file to ASCII rather than exporting it as text from here.

**Printer as destination.** If your exporting a metafile to the printer, pressing the **Print** button will produce the Windows® Print dialogue box, which lets you print as usual.



## The Different Graphs Available

The below screenshot examples of the available graphs are both shown in their standard look—no change of colours or other “tweaking” (as discussed in the above set of menus) has been applied.

The **Profile** tab shows the velocity profile in m/s and as amplitude in counts. The latter is an indicator of the strength of the received signal. For amplitude measurements, the counts-scale spans from 0 to 255. Typical noise level is around 20–30 counts. To give you an idea of how much a count is, suffice it to say that one count corresponds to approximately 0.4 dB. Hence, counts are logarithmic by nature.

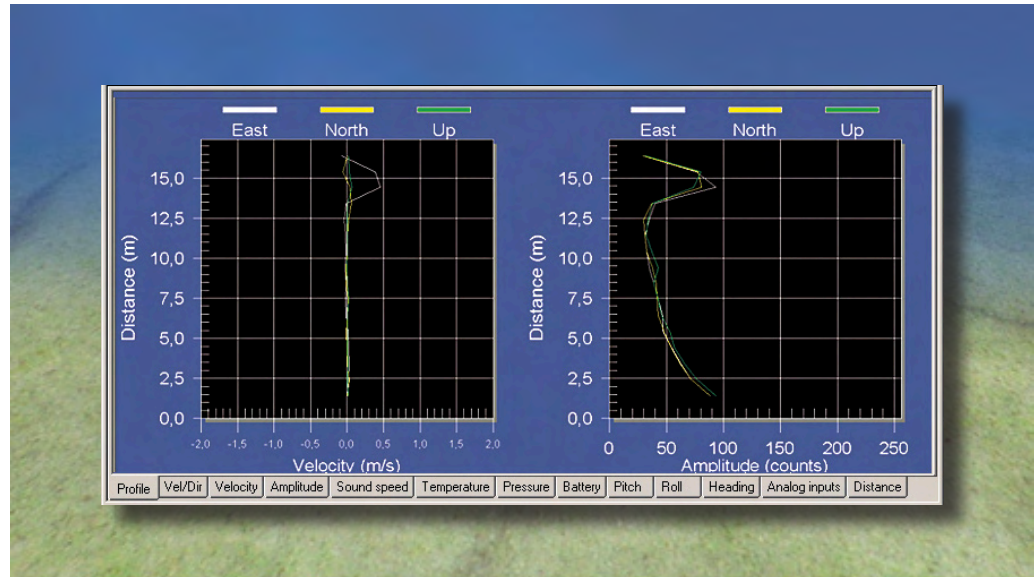

The **Vel/Dir** tab shows the combined velocity profile in **East/North** direction (**Up** is ignored). The corresponding direction is in degrees relative to North following traditional compass conventions so that positive (increasing) angles are clockwise (towards East). If you used XYZ, the direction angle will be relative to the X direction, but it will not follow the usual trigonometric conventions as compass conventions are preferred.

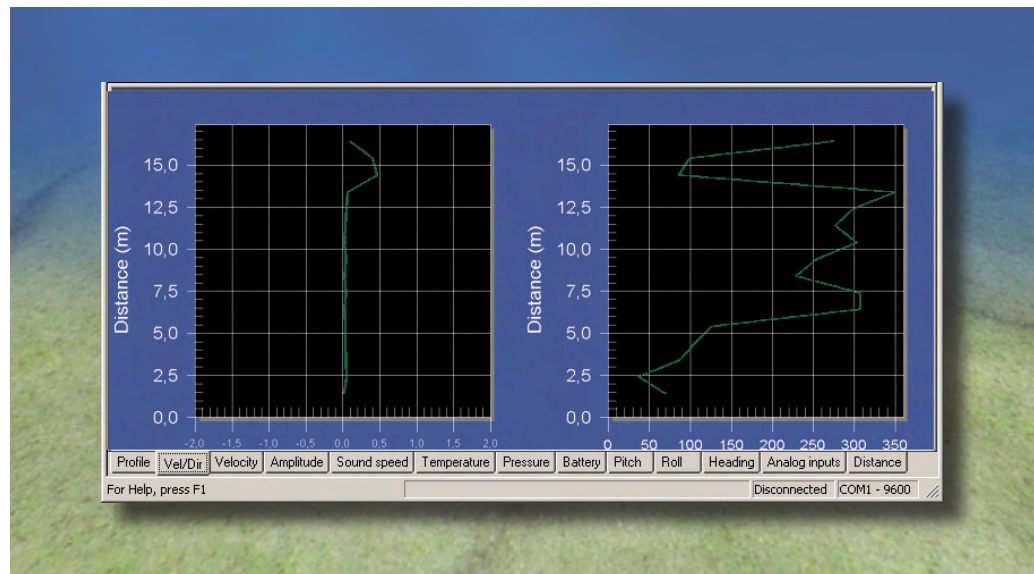

### Other displays available:

**Velocity tab.** The Velocity screen (not shown) displays the velocity of the first cell in accordance with the coordinates you specified in the deployment setup.

**Amplitude tab.** This screen (not shown) displays the velocity vs time of the first cell in counts (to indicate received signal strength) and in accordance with the coordinates you specified in the deployment setup.

**Soundspeed tab.** This screen (not shown) displays the sound speed vs. time. If your deployment setup uses fixed sound speed, this will be a flat line. If your deployment setup uses a keyed-in salinity and temperature, the sound speed will be calculated as the temperature changes. Note that any external CT sensors connected will be logged only. The information they provide will not be used in the Aquadopp's own measurement.

**Temperature tab.** This screen (not shown) displays the temperature vs. time based on the Aquadopp's internal thermometer.

**Pressure tab.** This screen (not shown) displays the pressure vs. time based on the Aquadopp's internal pressure sensor.

**Battery tab.** This screen (not shown) displays the battery voltage vs. time based on the Aquadopp's internal voltage measurement.

**Attitude tab.** This screen (not shown) shows the head, pitch, and roll of the Aquadopp vs. time.

**Analogue tab.** This screen (not shown) shows the signals received from analogue sensors connected to the analogue inputs of the Aquadopp.

# CHAPTER 8

## Getting Recorded Data out

---

This chapter explains how to get the data out of the Aquadopp Profiler by means of the AquaPro software. If you are going to do post processing in programs like Microsoft® Excel and MATLAB® the data must be converted to ASCII format first. This chapter shows you how.

### Retrieving Data from the Instrument

To retrieve data from the instrument:

- 1 Click **Deployment > Stop Recorder Deployment** or click the corresponding icon.

By clicking **Deployment > Stop Recorder Deployment** you will be able to compare the instrument's realtime clock setting time with that of the PC.

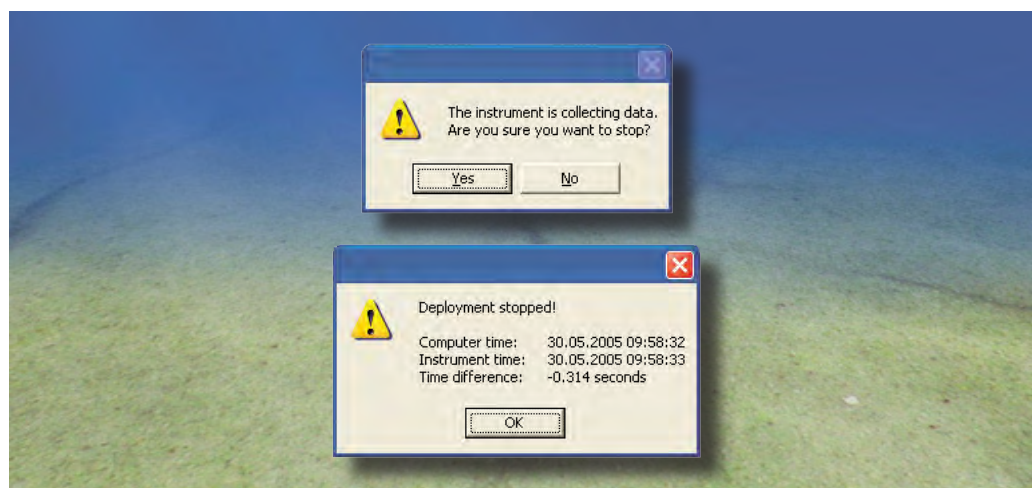

- 2 Click **Deployment > Recorder Data retrieval** or click the corresponding icon.

Within a moment, you will see a list of the recorded data files – in the case of more than one file, the most recent file will be the last one listed:

Recorder data retrieval. See also text for details.

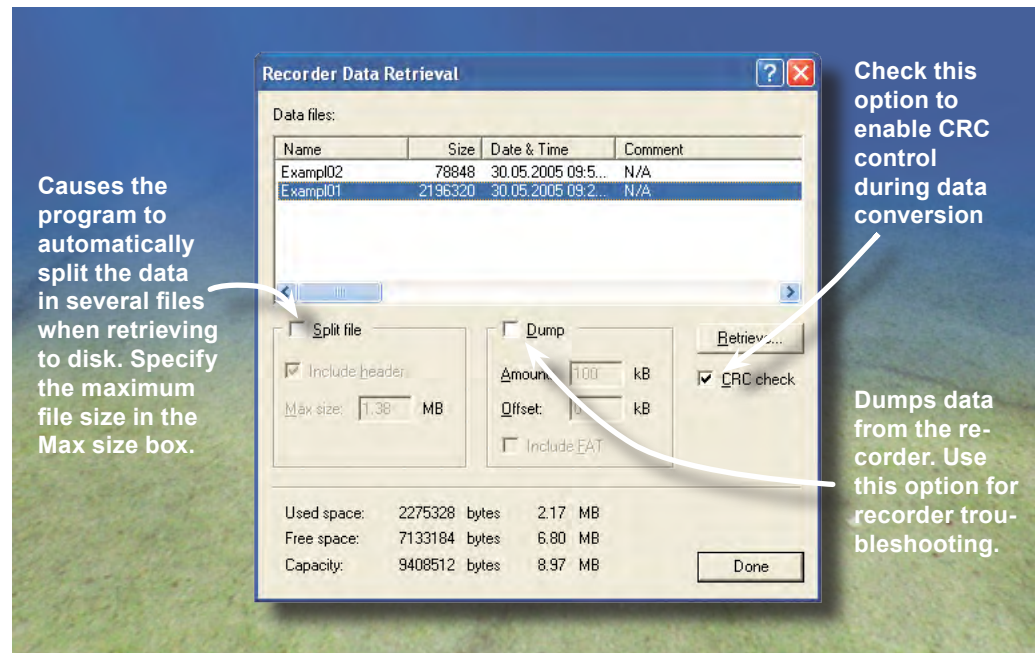

The following options are available:

- **Split file.** This option causes the program to automatically split the data in several files when retrieving to disk. Specify the maximum file size in the **Max size** box. Use this option to e.g. save data in disk files that will fit on floppy disks (max 1.38 Mb). The files will have a sequence number appended to their filename (e.g. mydata\_1.prf, mydata\_2.prf, ...).
- **Include header.** Includes header data with each file. If not checked, only the first file will have header data included.
- **Max size.** Specify the maximum split file size in Mbytes.
- **Dump.** Dumps data from the recorder. Use this option for recorder troubleshooting.
- **Amount.** Specify the number of kbytes to retrieve. Use this option for recorder troubleshooting.
- **Offset.** Specify a recorder position in kbytes from the start of the recorder for data dump.
- **Include FAT.** Includes the recorder file allocation table (FAT) in the dump file.
- **CRC check.** Check this option to enable CRC control during data conversion.

2 Highlight the file you want, click **Retrieve** and select the location for the file:

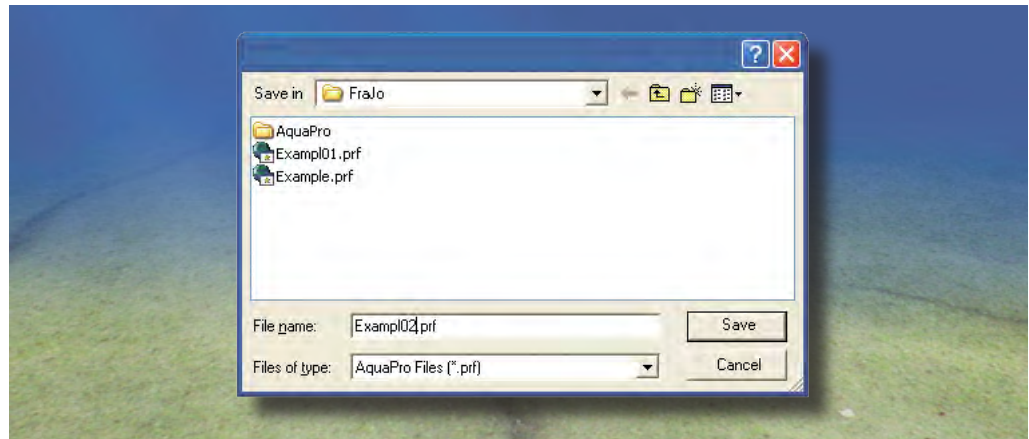

3 The selected file will now be retrieved and put on your hard drive.

## Converting to ASCII Format

To convert the retrieved data into ASCII format:

1 Click **Deployment > Data Conversion** or click the corresponding icon.

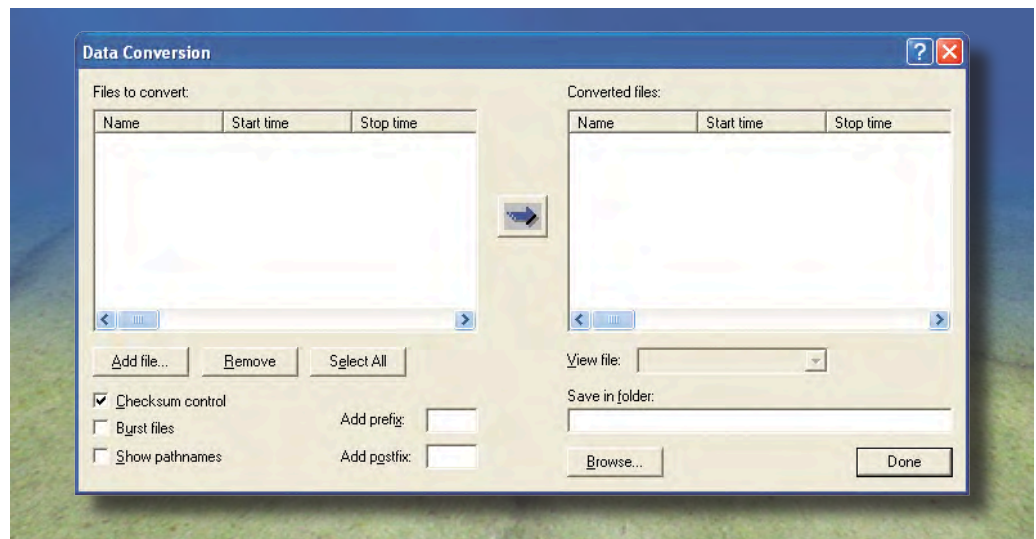

The following options are available:

- **Files to convert.** Lists files that may be selected for conversion. To convert files select items in the list and press the blue arrow.
- **Converted files.** Lists converted files.
- **Add file.** Displays a file selection dialog box where you can select files to add to the Files to convert list.

- **Remove.** Removes the selected files from the list.
  - **Select All.** Selects all files in the Files to convert list.
  - **Checksum control.** Performs checksum control during data conversion.
  - **Burst files.** Splits data collected in burst mode into separate files. The files will have a sequence number appended to their names.
  - **Show path names.** Shows files with full path names in file lists.
  - **Add prefix.** Specify text to be inserted in front of the recorder file name for the converted files.
  - **Add postfix.** Specify text to be appended to the recorder filename for the converted files.
  - **View file.** Selects a converted file in the drop-down list to open in Notepad.
  - **Save in folder.** Specify the location to put converted data files.
  - **Browse.** Displays a folder selection dialog box where you can select the location to put converted data files.
- 2 Define where to put the converted files (**Save in folder**). As default this is set to the same folder as the file to be converted resides in.

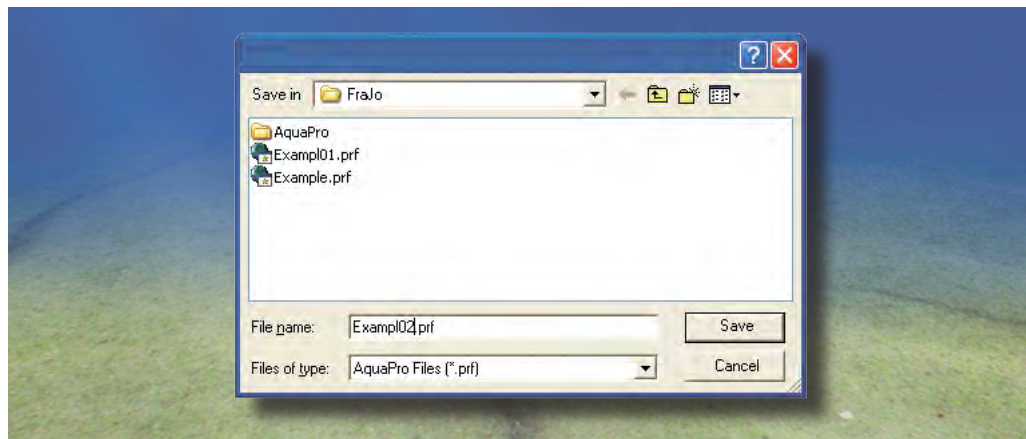

- 3 Click **Add file...** to insert files for conversion. Select files (use the **SHIFT** key and/or the **CTRL** key to select more than one file) and click **Open**.
- 4 Files selected will now be inserted in the left column. Repeat 3 if you want to convert files from other folders.

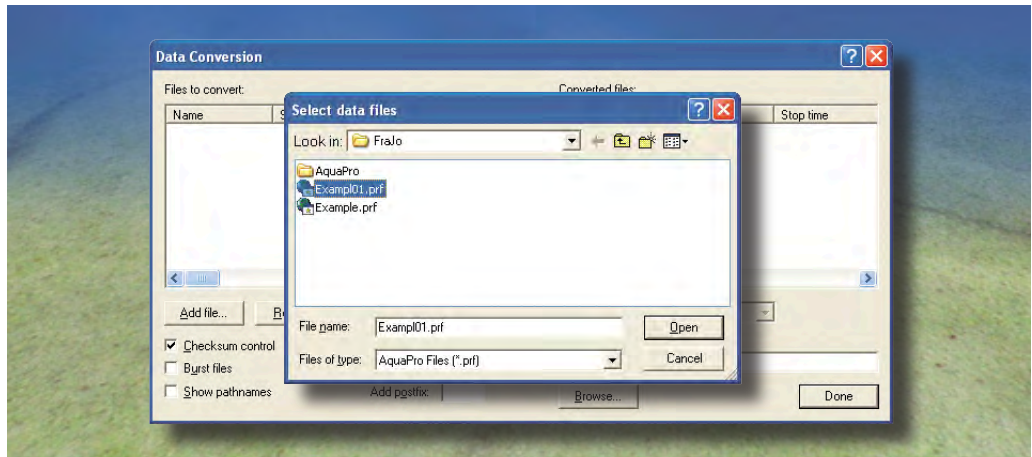

- 5 Once you have entered all the files required, highlight (by selecting) the files to be converted and click the arrow between the two columns:

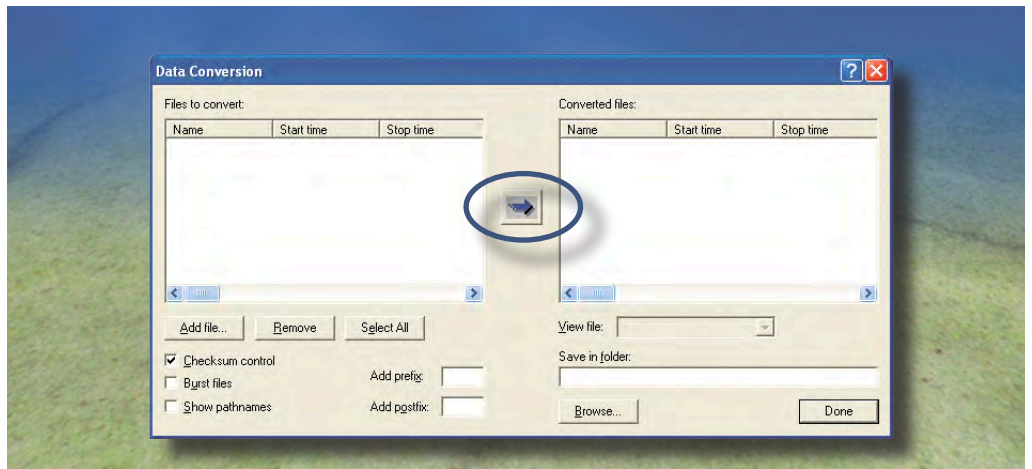

- 6 You will now be prompted to specify what part of the files you want to convert:

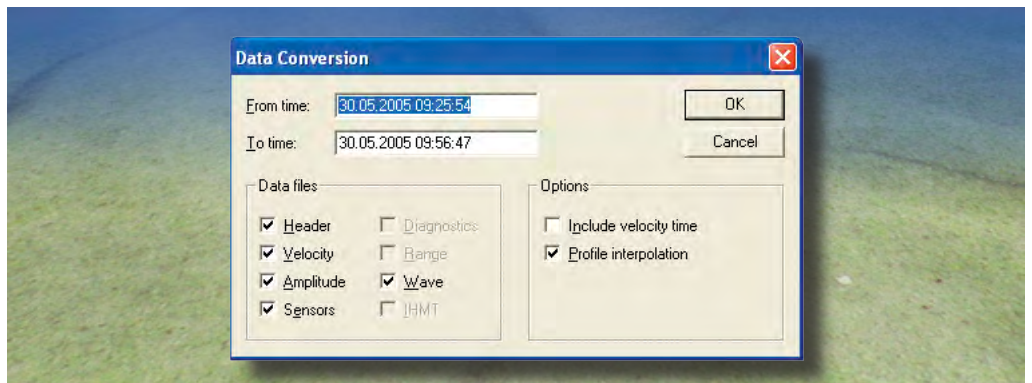

- To view the contents of a converted file, select what part or type you would like to inspect:

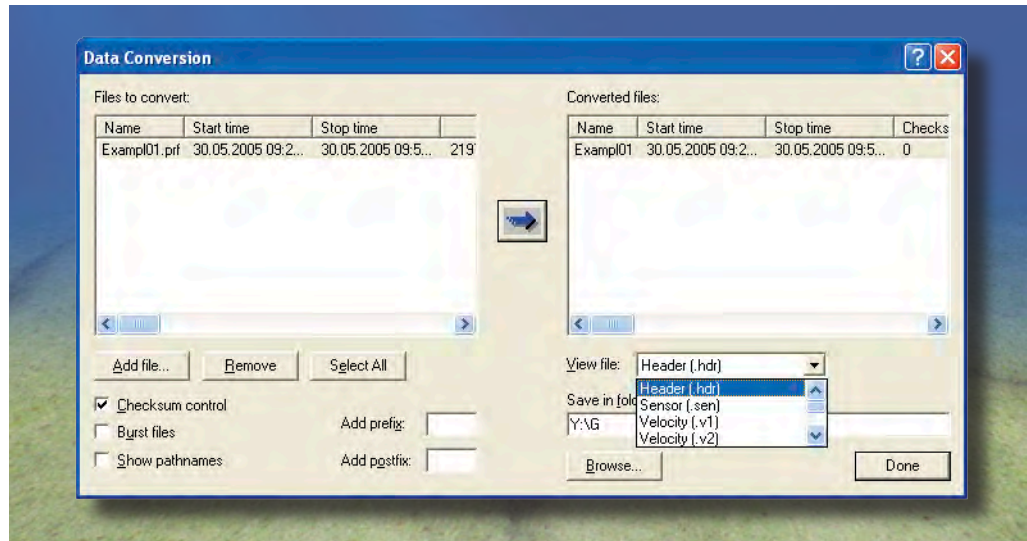

This will start Notepad (unless your PC is configured otherwise) and show the contents of the selected file:

The contents of a converted file is shown in Notepad on a Windows® 2000 system.

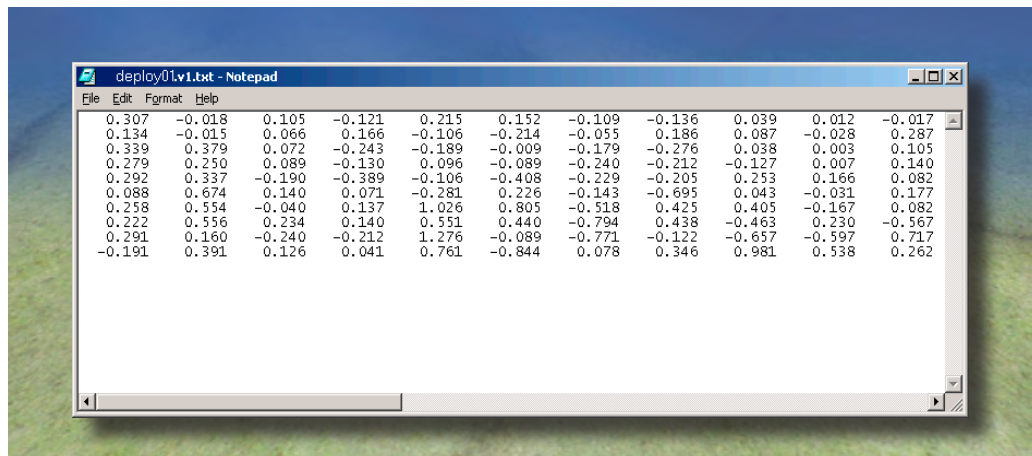

## Finish Operations

**Tip!** To conserve the batteries when the Aquadopp is not to be used for a period of time, be sure it is not in data acquisition mode.

Be sure to stop any data recording using one of the **Stop** buttons before you put the Aquadopp on the shelf or in the back of your car after use.

## Erasing Recorded Data

Erase the recorder by clicking **Deployment > Erase Recorder**. Before you do this, make sure that you have recovered your data, that the data file has not been corrupted and that you have stored a backup copy.



**Tip!** Use our web site (<http://www.nortek-as.com>) to get access to the latest tech-notes and user experiences regarding i.a. data analysis.

## Binary Data Files

Binary files created by the AquaPro program all use the same format, whether internally recorded or recorded using the real-time **Record to Disk** option. Binary data files include a header (50–100 bytes long), and each data record adds 32 bytes +  $9 \times N_{\text{CELLS}}$ . The binary file format is not documented here, since it is all shown in the header file – see example overleaf.

An example of parts of the header file showing that the data format is well documented in the header file itself. This will ensure that no matter how many firmware upgrades you do, you will always have access to the format used when the acquired data was downloaded.

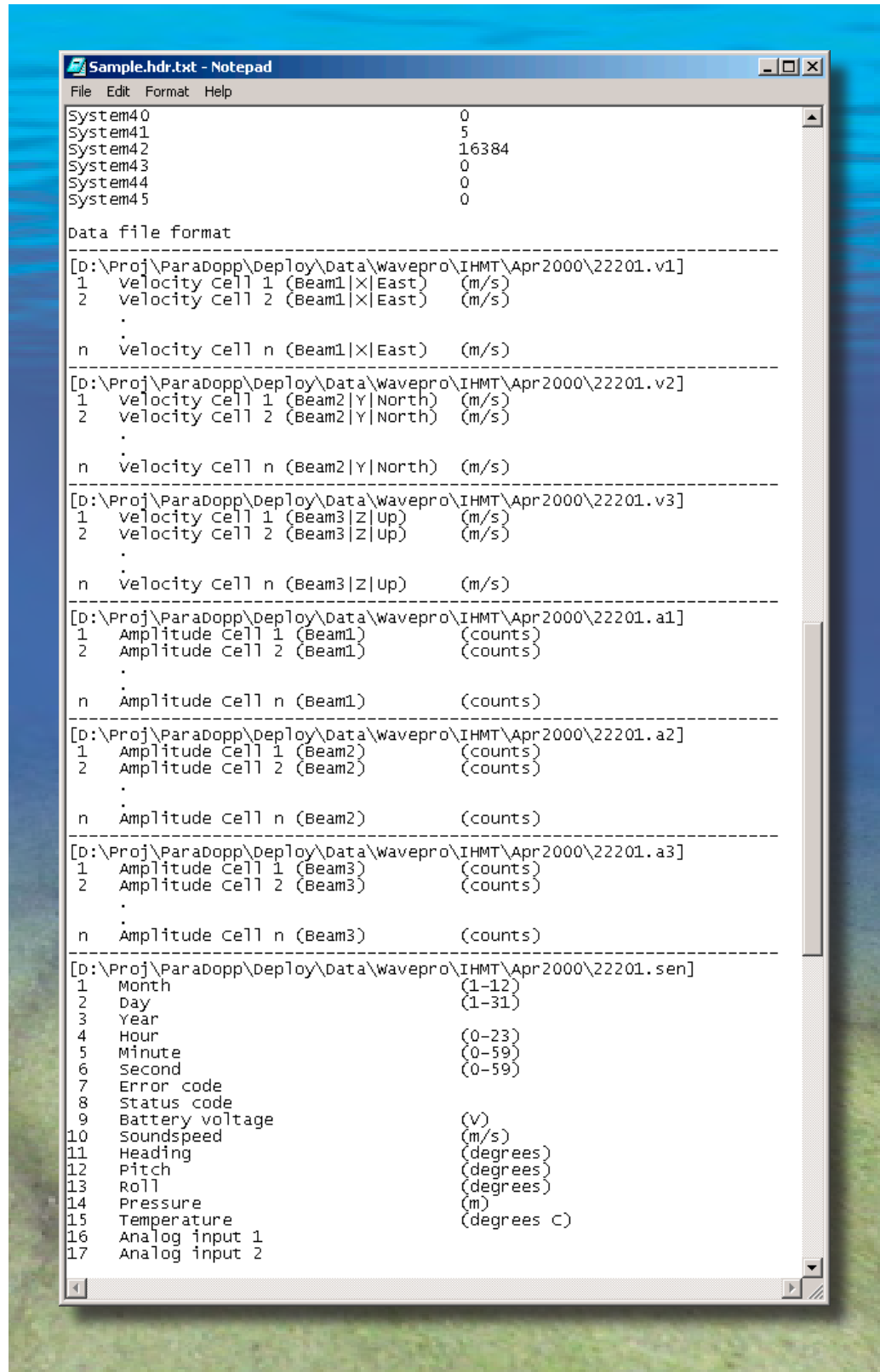

# CHAPTER 9

## Operational Concerns

---

### My Data Fails to Look Right

The Aquadopp Profiler cannot measure velocity properly if the water has too few scatterers. Your data will be questionable when signal levels are down around the noise level—which is about 20–30 counts for the 2 MHz version, 25–35 counts for the 1 MHz, and 30–40 counts for the 600 kHz version..

If your data doesn't look right, particularly if you have unrealistic vertical velocities, consider the possibility that one or more of the beams were blocked. If the blockage is somewhere inside the measurement cell of one beam, you should see elevated signal strength for that beam. If the blockage is closer to the instrument, the signal strength may not look very different from the other beams, or it could be substantially reduced.

**If you can collect data in real time while the instrument is deployed, do as follows to see if there are any obvious obstructions in any of the beams:**

- 1 Set up the instrument to measure using 1s measurement interval.
- 2 Select the **Profile** tab from the Data display selection bar.
- 3 Look for strong reflections.

### Correcting Data for Sound Speed Errors

If you enter the wrong salinity, the Aquadopp Profiler will compute an incorrect sound speed. You can correct velocities (**V**) for sound speed errors using the following equation:

$$V_{\text{NEW}} = V_{\text{OLD}} \frac{\text{New sound speed}}{\text{Old sound speed}}$$

Data already acquired cannot be corrected from within the Aquadopp software, so you will have to do this for yourself or add a correction term to all applicable values when importing ASCII converted data to Excel or MATLAB®.

### Boundaries and Sidelobes

Profilers looking up or down typically lose data near the surface or bottom. This loss is caused by contamination of the near-surface data by sidelobe echoes. The acoustic beams focus most of the energy in the centre of the beams, but a small amount leaks out in other directions. Because sound reflects much better from the water surface than it does from the water, the small signals that travel straight to the surface can produce sufficient echo to contaminate the signal from the water.

The geometry of profiler sidelobe interference. Only a few cells are shown for clarification. The top cell of the beam is shown as if it were extending into the air. This has been done to give a better indication of the surface position.

Note that  $\alpha$  is 25° for all Aquadopp Profilers.

- ☑ indicates cell OK
- ☒ indicates cell not OK

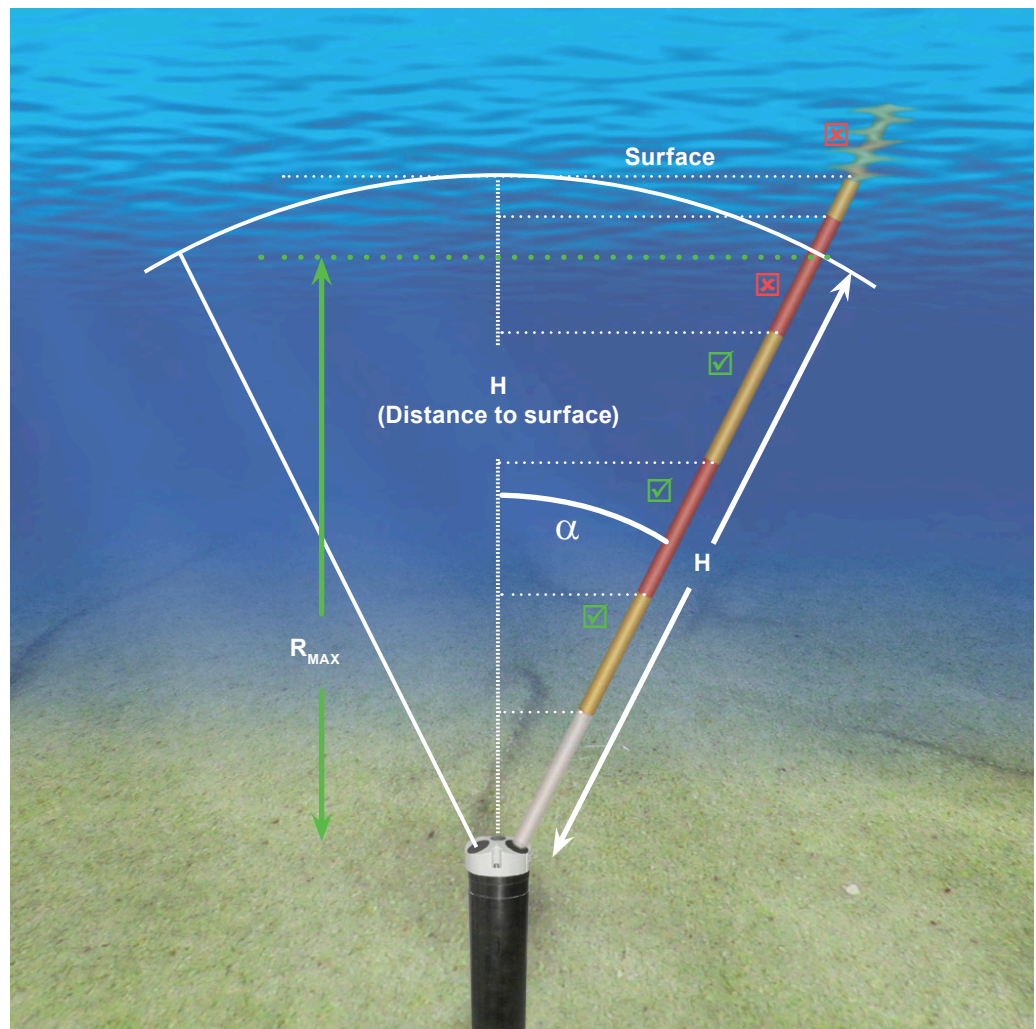

The above Fig. illustrates how this works. If the distance to the surface is  $A$ , then contamination of the current measurements at the same distance  $A$  along the slanted beams. In the Figure, the top two cells are contaminated. The following is an approximate equation for near-surface contamination:

$$R_{\max} = H \cos \alpha$$

where  $R_{\max}$  is the maximum range for good data,  $\alpha$  is the angle of the beam relative to vertical ( $25^\circ$  for all Aquadopp Profiler models), and **Cell** is the cell size. Note that in this context a cell is either good or contaminated—it cannot be partly OK. Consequently, the last good cell will be the one below the limit  $R_{\max}$ .

## Grounding Problems

Tests in laboratory tanks can sometimes lead to grounding problems, which show up as elevated noise levels, but only after the instrument is placed in the water. You will not automatically see the increased noise level in your data if your signal from the water is above the noise, but the increased noise level could look like signal.

Grounding problems is normally only a problem during the tests and velocity calibration. Feel free to contact Nortek for further guidance. Keep in mind that grounding problems occur around man-made structures, but are not normally a problem in the field.

## Mooring Tilt

Sometimes moorings tilt excessively or even fall over. If the Aquadopp Profiler's tilt reading is  $20^\circ$  or less, your data should be within the specifications. Tilt readings between  $20^\circ$  and  $30^\circ$  affect the data accuracy in a way that is likely to make the data fail to meet the specifications. Data acquired during tilts exceeding  $30^\circ$  are in general not reliable and should be discarded.

## Mooring Vibration

Excessive mooring vibration can adversely affect your data. Vibration introduces spurious velocities and interferes with the proper operation of the tilt sensor. If you discover that mooring vibration is a problem, you should try to find ways to reduce the vibration.

# Troubleshooting

## Simple Problems

Most initial problems can be traced to forgetting to power the system, the DB-9 connector falling out of the computer, or using the wrong serial port. Remember that new Aquadopp Profilers ship with the battery disconnected.

Computers don't always behave as they should and not all of them have serial ports available, so you may need to get a USB-RS 232 converter. If one computer is giving you a problem, try another one instead.

Power management can be a serious problem sometimes. If power management takes over the PC, data downloads can be disrupted sufficiently to cause the transfer to fail. Power management is most commonly enabled in laptop computers, but it can be enabled in desktops as well.

### Problems Detecting the Instrument on the Serial Port

If you cannot connect to the instrument, first try sending a break to the Aquadopp. Send a break by clicking **Communication > Terminal emulator**, and then clicking the **Send Break** button. If the Aquadopp is powered and properly connected, and if the terminal is set to use the correct serial port, then you will see the Aquadopp's wake-up message.

If you see a response consisting of garbled text or strange characters, then the Aquadopp and terminal program are probably using different baud rates—you could experiment by trying different baud rates (**Terminal > Serial port**). If you suspect your computer is having problems, try a different one. You can also verify your serial port and cable with a serial loop-back test (see below).

### Serial Loop-back Test

The serial loop-back test verifies that the serial port can receive the same characters it sends. First, make a loop-back connector (see the Fig. below) and plug it into your serial port. Run the test by typing characters—whatever you type should be echoed to the screen. When you remove the connector, the characters stop echoing back.

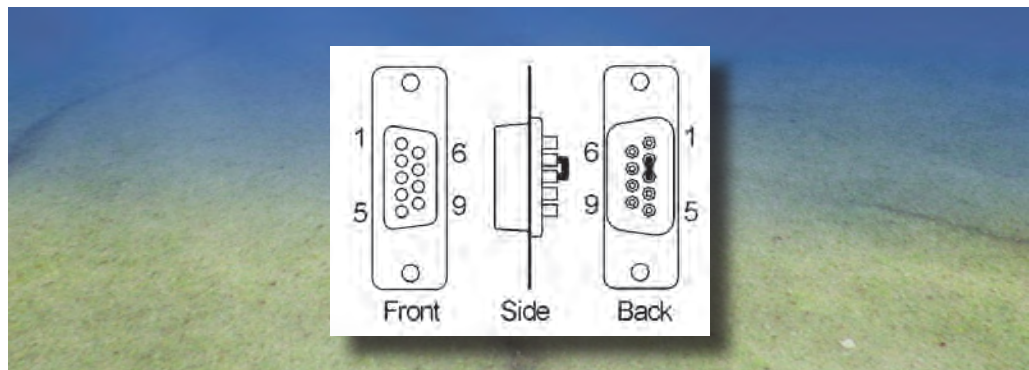

Run the test with the Aquadopp's built-in terminal emulator, and if that doesn't work, try HyperTerminal instead (a terminal program that comes with Windows).

Test your serial cable the same way. Plug the cable into the computer and put a loop-back connector on the end of the cable. If your serial cable passes the test and you still cannot wake up the instrument, there is a chance that your cable is a null modem cable—if so, it crosses wires 2 and 3. You can test this by substituting a different cable or by using a null-modem adaptor in series with the cable (which crosses wires 2 and 3 back).

# CHAPTER 10

## Maintenance

---

Before you assemble a system that involves custom cables, power supplies or the like, first assemble and test the Aquadopp using just the cables and battery that come with the system. This is the easiest way to get the system to work, and if you have trouble you can always return to this setup to confirm that problems are not caused by a faulty instrument.

### Preventive Maintenance

#### Cleaning

Perform regular cleaning of the Aquadopp Current Profiler. Use a mild detergent to clean the Aquadopp. Pay special attention to the transducers.

Check the pressure sensor and remove any dirt in the two front holes.

#### Antifouling

**Antifouling** paints and other agents are often used to avoid transducers getting covered with barnacles or other evil crustacés during long deployments. Depending on the water temperature, fouling can be a problem already after 2 weeks in tropical areas or it can take 6 months in cold areas. Sunlight is also a big factor—fouling is generally much less of a problem below 100 m than it is at 5 m.

Here are some things people do (quotes cut from various newsgroup postings and from emails we have received):

“In general when **antifouling** any [acoustic Current Profiler] for a long deployment we use plastic bags. Thin plastic bags of the type used as liners for small household or office bins work really well. Stretch them over the [acoustic Current Profiler] and then bind them in place with ducting tape. You need to put some tiny pinprick holes in the top of the bags so any trapped air can escape but the holes are too small to allow any organisms to enter.”

“We use zinc oxide as can be found in children’s ointments. A small amount on the high-frequency transducers and we see no sign of fouling.”

“We have been pleased with Pettit’s Trinidad anti-fouling paint (75.8% cuprous oxide).”

## Replacing the Desiccant

Keep water out of the open pressure case. Both fresh and salt water can corrode the circuitry.

At least once a year, replace the desiccant located behind the internal battery. Refer to the battery installation procedure for detailed information.

## Installing/Changing Batteries

Alkaline batteries should be degaussed before you use them in your instruments—you can do this yourself by placing the padded end of the battery up against the centre of your PC monitor (CRTs, not LCD screens) and using the monitor’s degaussing function.

Always be sure to include desiccant in the pressure case. Humid air can condense enough water to damage the electrical circuitry.



Use a CRT monitor and not an LCD monitor when degaussing alkaline batteries.

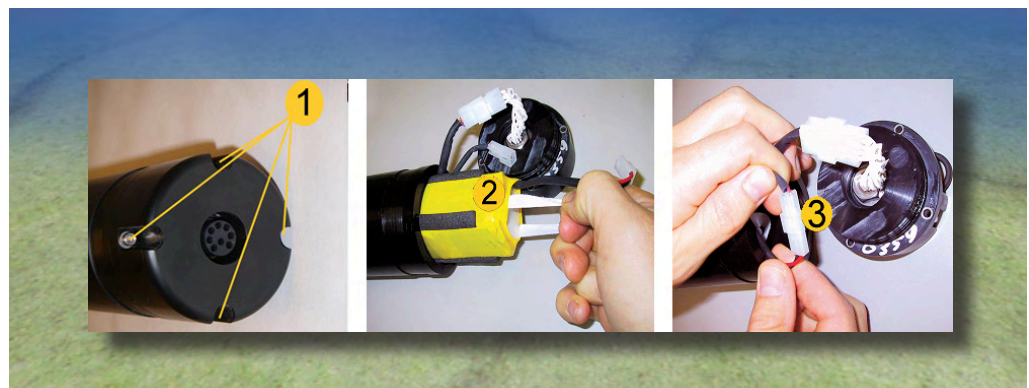

### To replace the battery pack:

- 1 Remove the four screws (1) and washers holding the end cap to the pressure case and remove the pressure case.



- 2 Disconnect the 2-pin connector (2) and pull the old battery (3) out of the pressure case.
- 3 Slide in a new battery and connect it to the 2-pin connector.
- 4 Insert the end cap to the pressure case and mount the four screws and washers. Tighten the screws carefully to avoid damaging the threads in the pressure case. Tighten the screws only until the end-cap touches the pressure case and you can just feel that they are seated. Keep in mind that ocean pressure holds the end cap in tightly – all the screws have to do is to keep the end cap from falling out when the system is above water.

Take care when handling the O-ring and the O-ring surfaces.

- 5 Test communication with the Aquadopp's built-in terminal emulator program by sending a 'break' command to the instrument. If it is wired correctly then you should see the Aquadopp's wake-up message on the screen (it will give you the model of your instrument plus the firmware version number). If you get a string of garbage characters try another baud rate setting. When the instrument responds to a 'break' properly then the communication lines are correctly connected. An easy alternative for using the terminal emulator is to read the configuration file directly from the instrument (**Deployment > Planning > Load from instrument**). If the instrument is set for a different baud rate than the software expects, it will search for the correct baud rate and connect automatically.
- 6 Test the instrument by collecting data without using an external power source to ensure that the battery is properly connected. Make sure to stop data collection so that the instrument will power down after you are through testing it.
- 7 Check and/or reset the clock if necessary.
- 8 Because the battery pack uses standard alkaline batteries, you do not normally need to observe any special precautions when you dispose of old batteries

If you have lithium batteries, keep in mind that you must be very careful and that disposal requires special precautions and/or procedures. Legislation for disposal of batteries, especially lithium batteries, vary from country to country.

## Corrective Maintenance

Only qualified personnel are allowed to perform corrective maintenance activities. Please refer to the separate service manual or contact NORTEK for further assistance.



## APPENDIX

# Returning Aquadopp for Repair

---

Before any product is returned for repair you must have obtained a Return Merchandise Authorization (RMA) in writing from Nortek AS.

Copy the Proforma Invoice template overleaf, or make your own, but be sure to include all the information requested in the Proforma invoice.

Also, be sure to include a copy of all shipping and export documents inside the freight box.

**Important!** Freight insurance on repairs is *not* covered by Nortek AS. You must make sure your goods are properly insured before shipment. Nortek AS is by no means liable if the instrument is damaged or disappear while being shipped to Nortek AS for repair. Likewise, Nortek AS is not liable for consequential damages as a result of instruments becoming damaged or disappearing while being shipped to Nortek AS for repair.

Nortek AS will insure the instrument upon returning the goods to you and invoice you for this, along with the repair- and freight costs.

If the instrument is under warranty repair, the transport and freight insurance from Nortek AS back to you will be covered by Nortek AS.

# Proforma Invoice



SENDER (Exporter)	
Name:	<input type="text"/>
Address:	<input type="text"/>
City:	<input type="text"/>
Country:	<input type="text"/>
Tel.:	<input type="text"/>
Fax:	<input type="text"/>
Ref.:	<input type="text"/>

RECEIVER	
Name:	Nortek AS
Address:	Vangkroken 2
City:	NO-1351 Rud
Country:	Norway
Tel.:	+47 67174500
Fax:	+47 671367 70
E-mail:	inquiry@nortek.no
Contact:	Jonas Røstad

About the Goods	
Date: <input type="text"/>	No. of Units: <input type="text"/> Weight: <input type="text"/>
Delivery Terms: <input type="text"/>	Customs Account No.: 28605-56
Description of Goods: <input type="text"/>	Origin: NO Value: <input type="text"/>
	Total Value: <input type="text"/>
	Nortek RMA No: <input type="text"/>
Reason for Export: <input type="text"/>	
Scientific instrument temporarily returned for repair. Customs classification: 9015.90.90	

Date: _____	_____
	Exporter's signature



